

# EFC5A/EFC5B SERIES

## BATTERY CABINET

INSTALLATION, OPERATION, AND MAINTENANCE MANUAL

---



This manual provides instructions regarding safety, storage, installation, operation and maintenance. Failure to observe the precautions as presented may result in injury or loss of life.

This document is proprietary to Electronic Systems Support (ESS). This document cannot be copied or reproduced in whole or in part, nor can its contents be revealed in any manner or to any person except to meet the purpose for which it was delivered, without the express written permission of Electronic Systems Support.

Please visit [ess.to](http://ess.to) to check for updates to manual.



## TABLE OF CONTENTS

1. INTRODUCTION .....	2
2. PRECAUTIONS.....	2
3. INSPECTION UPON RECEIPT OF GOODS .....	3
3.1 General .....	3
3.2 Visible damage .....	3
3.3 Concealed damage .....	3
3.4 Return of damaged goods .....	3
4. SYSTEM OVERVIEW .....	3
5. GENERAL SYSTEM SPECIFICATIONS.....	4
5.1 DC Output Characteristics .....	4
5.2 Batteries.....	4
5.3 Grounding.....	4
5.4 Environmental Conditions.....	4
• Cabinet Dimensions .....	4
• Cabinet Weights (Assembled) .....	5
6. INSTALLATION PROCEDURES.....	5
6.1 Preparation .....	5
6.1.1 Necessary Equipment and Tools .....	5
6.1.2 Equipment Inspection .....	5
6.1.3 Safety Precautions .....	6
7. INSTALLATION STEPS .....	6
7.1 Cabinet Location.....	6
7.2 Cabinet Mounting .....	6
7.3 DC Connections .....	7
7.4 Grounding.....	7
7.5 System Operation.....	7
8. SYSTEM MAINTENANCE.....	8
8.1 Blown Fuse Replacement.....	8
8.2 Battery Replacement Steps.....	8
9. WARRANTY RELATED MAINTENANCE	
10. DRAWINGS/SCHEMATICS .....	9
• General Cabinet Drawing.....	10
• Anchor Specifications .....	11
• Anchor Placement Dimensions.....	12-13
• 480V, EFC5A Top Breaker – Mechanical/Electrical Drawing.....	14
• 384V, EFC5A Top Breaker – Mechanical/Electrical Drawing.....	15
• 384V, EFC4A Top Breaker – Mechanical/Electrical Drawing.....	16
• 288V, EFC4A Top Breaker – Mechanical/Electrical Drawing.....	17
• 480V, EFS5A Side Breaker – Mechanical/Electrical Drawing.....	18
• 384V, EFS5A Side Breaker – Mechanical/Electrical Drawing.....	19
• 480V, EFC5B Top Breaker – Mechanical/Electrical Drawing.....	20
• 384V, EFC5B Top Breaker – Mechanical/Electrical Drawing.....	21
• 384V, EFC4B Top Breaker – Mechanical/Electrical Drawing.....	22
• 288V, EFC4B Top Breaker – Mechanical/Electrical Drawing.....	23
• 480V, EFS5B Side Breaker – Mechanical/Electrical Drawing.....	24
• 384V, EFS5B Side Breaker – Mechanical/Electrical Drawing.....	25
• Notes Page .....	26
• Notes Page .....	27











## 1. INTRODUCTION

ESS EFC5A AND EFC5B Series Front Terminal Battery Cabinets are shipped partially assembled, internally pre-wired and come standard with an over current breaker. The removable hinged front doors and removable rear cover also allow for easier battery access. Maintenance rear covers are not needed since all batteries come with nylon straps for easier lifting and moving. Refer to the battery layout drawings and schematics at the end of this manual. Consult the battery manufacturer's battery operation and maintenance manual for complete instructions.

These battery systems are Hi-Pot tested to UL 1778 standards at the factory prior to shipment. All system settings are also adjusted at this time according to the specification sheet. Sales support for future equipment or upgrades is provided by our sales staff and qualified representatives. All technical questions and service issues should be directed to our office 972-272-2468.

## 2. PRECAUTIONS

-  **It is very important to read, understand and follow the instructions in this manual. Also note all SAFETY PRECAUTIONS before beginning the installation of this system.**
-  **Consult the Battery Manufacturer's Operation and Maintenance Manual for important battery information.**
-  **Battery cabinet systems are very heavy. Total weight of a loaded dual cabinet can exceed 8900 lbs. while single cabinets can weigh up to 5400 lbs. Use at least 3 people when unloading and setting equipment in place.**
-  **It is imperative that only qualified personnel work on this system and installation, maintenance or upgrades be performed with insulated tools and equipment.**
-  **When installing this battery system, follow all applicable federal, state and local regulations and industry guidelines to insure a proper installation.**
-  **DC power and battery supplies are dangerous and have extremely high short circuit currents. Severe burns or death can result from a system short. They also can leak potentially explosive gas (hydrogen). Never enclose batteries or battery cabinets in a sealed air tight room.**
-  **All jewelry and watches must be removed prior to installing or servicing this system.**
-  **Do not smoke or present flame near or around any battery cabinet system.**
-  **Never leave a panel off or door open and unattended.**

## 3. INSPECTION UPON RECEIPT OF GOODS

### 3.1 General

Special precautions and care have been taken to ensure the cabinet system arrives safe and undamaged. However, upon receipt, you should inspect the entire shipment, including the crate and any boxes for evidence of damage that may have occurred during transit.



### 3.2 Visible Damage

It is the responsibility of the person receiving the shipment to inventory and fully inspect all materials against the bill of lading or way bill IMMEDIATELY, while the carrier representative is still present. Ensure that all items are accounted for, including number of skids and quantity of boxes. Also note any visible external damage that may have occurred during transit. Make all applicable notations on the delivery receipt before signing and file a damage report with the carrier.

### 3.3 Concealed Damage

Within 30 days of receipt, unpack the cabinet system and check for any concealed damage. Check the materials received against the detailed packing list to verify the quantity and the condition as complete and satisfactory.

Note any damage to the internal packaging, then request an inspection by the carrier and file a concealed damage claim. If there is a material shortage, contact ESS at the number listed at the end of this manual.

**Please contact your shipping company for all shipping damage. ESS is not responsible for any shipping damage.**

### 3.4 Return of Damaged Goods

A RMA number must be obtained before returning equipment to ESS. Please contact an ESS representative or call the corporate number listed at the end of this manual.

## 4. SYSTEM OVERVIEW

The enclosed cabinet systems provide the necessary DC backup power required in UPS applications. Over-current breaker/fuse protection is supplied. DC connections are front accessible and made via terminal blocks and/or mechanical lugs. Refer to the drawings and schematics at the end of this manual for these connections. Cabinets are equipped with 3-pole breakers. There are 2 holes per polarity on 300 Amp to 600 Amp breakers. Breakers 30 Amps to 250 Amps have a single hole per polarity. **See table below for standard output lug sizes of breakers.**

BREAKER SIZING						
BREAKER SIZE AMPS	30A	40A	50A	75A	100A	125A
A.I.C. RATING, 500DC	20,000 A.I.C	20,000 A.I.C	20,000 A.I.C	20,000 A.I.C	20,000 A.I.C	20,000 A.I.C
OUTPUT LUG SIZE	(1)#14-3/0	(1)#14-3/0	(1)#14-3/0	(1)#14-3/0	(1)#14-3/0	(1)#4-3/0
BREAKER SIZE AMPS	150A	175A	200A	225A	250A	300A
A.I.C. RATING, 500DC	20,000 A.I.C	20,000 A.I.C	20,000 A.I.C	20,000 A.I.C	20,000 A.I.C	20,000 A.I.C
OUTPUT LUG SIZE	(1)#4-4/0	(1)#4-4/0	(1)3/0-350	(1)3/0-350	(1)3/0-350	(2) 2/0-500
BREAKER SIZE AMPS	350A	400A	450A	500A	600	
A.I.C. RATING, 500DC	20,000 A.I.C	20,000 A.I.C	20,000 A.I.C	20,000 A.I.C	20,000 A.I.C	
OUTPUT LUG SIZE	(2) 2/0-500	(2) 2/0-500	(2) 2/0-500	(2) 2/0-500	(2) 2/0-500	

During normal conditions the UPS supplies the load power and the necessary power required to keep the batteries at the proper float voltage. Verify that the charger is set to charge parameters within the approved float voltage range of the batteries, refer to manufacturer's battery operation and maintenance manual.

When AC fails, the batteries discharge in order to provide the necessary backup power. It is the responsibility of the customer to make sure the batteries are not discharged below the battery manufacturer's recommendations. Always recharge batteries per manufacturer's battery operation and maintenance manual. Batteries will be damaged if not recharged right away. See the UPS or DC system manual for more information.



## 5. GENERAL SYSTEM SPECIFICATIONS

### 5.1 DC Output Characteristics

- **Voltage:** (UPS Application) 288 to 480 VDC Nominal
- **Breaker:** Standard
- **Fuse Type:** Not standard, consult factory. If a fuse is provided, it is only to be replaced by a factory service technician.

**CAUTION! Fire Hazard Warning:**  
**Replace only with same type and rating of fuses supplied with the system.**

- **Wire Size and Type:** Per NEC and/or local building and electrical codes.
- **Disconnect:** If a fuse has been provided in lieu of a breaker inside the cabinet, a disconnecting method must be provided per NEC code. This may be a fuse switch or circuit breaker. Size accordingly.

### 5.2 Batteries

- **Type:** Valve Regulated Lead Acid (VRLA), sealed, non-spillable.
- **Voltage:** 16 Volt DC Nominal, Front Terminal Design.

UL approved battery models:

Energys : 16HX550F-FR, 16HX800F-FR, 16HX925F-FR

- **Only cabinets with flame retardant batteries are suitable for computer room use!**

### 5.3 Grounding

- All grounding should be derived from the main building ground source.
- **Note:** All cabinet systems require grounding.

### 5.4 Environmental Conditions

Breakers are located at the top of the cabinet for EFC configurations. For EFS configurations, the breakers are located on the side of the cabinet. EFC5x and EFS5x cabinets have a maximum battery configuration of 6 wide by 5 tiers high. EFC4x cabinets have a maximum battery configuration of 6 wide by 4 tiers high.



## Nominal Cabinet Dimensions:

EFC5A, Top Breaker is 49.6" W x 31.5" D\* x 84.0" H  
EFC4A, Top Breaker is 49.6" W x 31.5" D\* x 72.0" H  
EFS5A, Side Breaker is 61.8" W x 31.5" D\* x 72.0" H  
EFC5B, Top Breaker is 31.4" W x 31.5" D\* x 84.0" H  
EFC4B, Top Breaker is 31.4" W x 31.5" D\* x 72.0" H  
EFS5B, Side Breaker is 43.6" W x 31.5" D\* x 72.0" H

For mounting hole dimensions, please refer to the cabinet layout drawing at the end of this manual. Also included with each order is a floor template to mark anchor locations per cabinet.

\*All depth dimensions are of cabinet minus the breaker handle. For cabinets with the optional breaker handle, add 2.5 inches to the depth listed above.

## Max Cabinet Weights: (Assembled)

Reference the drawings for each individual voltage available for cabinet weights depending on battery manufacturer and model.

- **Temperature:** Normal operating temperatures are between 68°F -77°F. **Note:** Batteries typically should be at 77°F for optimum battery life and performance.
- **Ventilation/Cooling:** Provided through ventilation slots in the rear panel, bottom panel, front door and top of cabinet, thus providing a chimney effect for natural convection cooling. If local codes require forced air exhaust, unused covers serve as conduit entry or duct work entry points.
- **Clearance:** A minimum of four inches is required in both the front and the rear of the cabinet. This refers to obstruction of ventilation only. Clearance around cabinet sides is suggested by NEC and local codes.

**CAUTION! Explosion/Fire Hazard Warning:**  
**Batteries can generate potentially explosive gas (hydrogen).**  
**Never enclose batteries or battery cabinets in a sealed, airtight room.**

## 6. INSTALLATION PRODEDURES

### BEFORE PROCEEDING WITH INSTALLATION READ THE FOLLOWING:

#### 6.1 Preparation

##### 6.1.1 Necessary Equipment and Tools

- Rigging tools for moving cabinets. Narrow pallet jack and forklift of 5,500 lbs. minimum capacity when moving fully loaded cabinets.
- Heavily insulated assortment of hand tools.
- Digital Voltmeter

##### 6.1.2 Equipment Inspection

Remove the packaging material from the cabinet and inspect for any concealed shipping damage that may have been overlooked upon receipt of goods. Use the packing list to verify the system has all components and cables for installation.













### 6.1.3 Safety Precautions

#### **DC VOLTAGE WARNING!**

Hazardous DC Voltages are present in the battery cabinet. This hazard will always be present, even when the battery system is off-line. Accidental short circuit of the positive and negative terminals will cause tremendous currents to flow resulting in severe burns, fire and possible death. Use extreme caution!

#### **IMPORTANT SAFETY INSTRUCTIONS. SAVE THESE INSTRUCTIONS!!**

-  All disconnecting means should be in the open/off position before servicing.
-  All installation drawings and schematics should be reviewed and clearly understood before hooking up this system.
-  Only qualified DC power technicians or electricians should attempt to work on and install this equipment.
-  All jewelry, rings and watches should be removed when working on this equipment.
-  All tool handles and shafts must be heavily insulated.
-  Do not rest any tools or loose cables on top of batteries.
-  Make sure all connections are properly torqued and secure. Torque values are provided on battery label.
-  Do not smoke or present flames near or around any battery system.
-  Always wear safety glasses and gloves and use insulating mats to stand on when working on this system.
-  Do not allow bare skin to come into contact with battery cabinet, as this could result in an electrical shock.
-  Do not install any cable terminations until it has been verified that such a termination will not create a short circuit.

## 7. INSTALLATION STEPS

### 7.1 Cabinet Location

Prior to installation, verify floor loading requirements and all applicable codes pertaining to the related equipment. Environmental conditions should also be reviewed. Proper ventilation and cooling must be adequate for optimum battery life and performance. A clearance of 4" is recommended at the front and rear of the cabinet. This refers to obstruction of ventilation only. Clearance around the cabinet sides should be as suggested by NEC and local codes. Ambient temperature should be between 68°F -77°F.

### 7.2 Cabinet Mounting

1. Remove any remaining packaging materials (cardboard, plastic).
2. Remove the kick plate from the base of the cabinet. Save this kick plate for re-installation later.
3. Unbolt the cabinet from the pallet. Remove the cabinets from the pallet using a forklift rated for at least 5,500 lbs.
4. The battery cabinet is equipped with narrow pallet jack or forklift access openings in the front and rear of the cabinet. Move the equipment into the desired location and set in place.  
**Note:** When applicable, the cabinet labeled "Left" has the breaker and those cabinets should be paired with any of the "Right" labeled cabinets.





5. In order to meet Zone 4 requirements, refer to the Zone 4 ANCHORING drawings included with this manual. The following steps detail the necessary actions to be taken to meet Zone 4 mounting requirements. Check applicable building codes for length and style of anchors to be used with the flooring substrate. Install anchors per manufacturer's instructions.
6. On the floor, mark the location of the 6 mounting holes found at the bottom of the cabinet legs.
7. Use the floor template or hole location drawing provided with each shipment to mark holes for anchors. Use ½" or 13mm anchors. Install anchors per manufacturer's instructions.
8. Move the cabinet into place, align holes, check levelness, and tighten hardware. **Note:** Should any drilling be performed on this equipment, make sure all exposed batteries and connections are completely covered using insulated type mats. Prevent dust from entering cabinets and clear any debris that has collected.
9. Re-install the front kick plate on the cabinet.
10. Install the front doors on the cabinet.
11. If multiple battery cabinets are installed, repeat above steps. Check height and levelness with adjoining cabinets.

### 7.3 DC Connections

**CAUTION!**  
**PLEASE READ ALL SAFETY INSTRUCTIONS BEFORE PROCEEDING.**

1. Open the cabinet door and check for any noticeable problems or damage that may have occurred during shipment. Remove the cardboard box from the cabinet (right cabinet in a dual cabinet system). Use the packing list to verify all bus bars, cables, battery covers and hardware required for assembly is available.
2. Review the installation drawing and schematic diagram included in this manual. Cables and bus bars have been left off in the battery string for safety and will need to be installed later.
3. Connect main cables to the circuit breaker, when applicable, inside the cabinet from the UPS or charger source. All cables should be sized per NEC and any other local codes pertaining to this equipment. Refer to the UPS or charger manual for wiring external batteries. **Note:** Make sure charging source is disconnected before making these connections; also verify the battery cabinet is turned off.
4. Connect the battery interconnect bus bars that were left off during shipment and install as shown on the installation drawing included in this manual. Torque connections properly. Torque values are provided on battery label.
5. Install plastic covers onto batteries. Some covers may need to be notched for locations with bus bars and/or cables in upward orientation.

### 7.4 Grounding

Ground the battery cabinet to the main building ground. A ground stud inside the cabinet is provided for this. In dual cabinet strings for the 16HX800f/16HX925F batteries, a bare copper bus bar is supplied to be installed between the tops of the battery cabinets. Threaded holes are provided in the cabinets for easy connection of the bus bar. Make sure a clean ground is present before bolting down bus bar.

### 7.5 System Operation

Refer to the UPS or charger manual for start up and operation of system.



## 8. SYSTEM MAINTENANCE

**CAUTION!**  
**PLEASE READ ALL SAFETY PRECAUTIONS BEFORE PROCEEDING**

### 8.1 Blown Fuse Replacement

If a fuse has blown in the system, contact an authorized factory technician to replace it.

**CAUTION! Fire Hazard Warning:**  
**Replace only with same type and rating of fuses supplied with the system.**

### 8.2 Battery Replacement Steps

Servicing of batteries should be performed or supervised by personnel knowledgeable about batteries and the required precautions. When replacing batteries, replace with the same type and number of batteries.

**CAUTION!**  
**Do not dispose of batteries in a fire. The batteries may explode.**  
  
**Do not open or mutilate batteries. Released electrolyte is harmful to the skin and eyes.  
It may be toxic.**

A battery can present a risk of electrical shock and high short-circuit current. The following precautions should be observed when working on batteries:

- Remove jewelry, rings, watches or other metal objects.
  - Use tools with insulated handles.
  - Wear rubber gloves and boots. Wear safety glasses.
  - Do not lay tools or metal parts on top of batteries.
  - Disconnect charging source prior to connecting or disconnecting battery terminals.
  - Determine if the battery is inadvertently grounded. Remove string from buss and check voltages to ground. Contact with any part of a grounded battery can result in electrical shock. The likelihood of such shock can be reduced if such grounds are removed during installation and maintenance (applicable to equipment and remote battery supplies not having a grounded supply circuit).
1. Prepare the new battery for installation. Check to make sure the battery is the same type and amp-hour rating. Use a non-metallic brush or scotch brite pad to clean the terminals. Apply a light coat of No-ox grease to the terminal to avoid corrosion "per battery manufacturer's recommendation".
  2. Disconnect the charger or UPS from the battery string by opening the breaker.
  3. Remove the center jumper on the battery string to reduce the voltage. If replacing all batteries, continue reducing the voltage in this manner.
  4. Disconnect the interconnect bus bars and/or cables from the battery to be replaced.
  5. Remove the old battery.
  6. Install the new battery. Make sure the new battery is installed the same way regarding polarity orientation and verify with drawing.



7. Reconnect bus bars and/or cables to the battery. Make sure connections are properly torqued. Torque values are provided on the battery label.
8. Reconnect the center jumper. Make sure connections are properly torqued. Torque values are provided on the battery label.
9. Check voltage at terminal block.
10. Close breaker when ready. If your model has a disconnect with an exterior handle to the door, close and latch the door first before closing the breaker.

## **9. WARRANTY RELATED MAINTENANCE**

1. The purchaser (user) shall give freshening charges to the battery a minimum of every six (6) months for Lead-Calcium batteries after shipment from the factory and until final installation. Refer to the installation and maintenance instructions for maximum storage intervals at different environmental situations. Extreme heat could cause more frequent freshening charges.
2. At least once every twelve (12) months, purchaser (user) must take readings and record information per battery manufacturer's installation/maintenance instructions. These records must be maintained for warranty claim purposes. If warranty records are not kept, the warranty shall be null and void.
3. Parallel strings should be limited to five (5) strings
4. Movement of batteries from original point of installation shall immediately void the product warranty, except with the expressed written consent from ESS.
5. Any storage shall be in a dry area having ambient temperature of 77° F (25° C), or less, and in accordance with battery manufacturer published installation, operation and maintenance instructions. Failure to follow the battery manufacturer's published guidelines and/or instructions may invalidate the product warranty, at the sole discretion of ESS.
6. During service or extended storage, a battery system monitor is recommended to be used to record temperatures, voltages, AC ripple, Float currents, Discharge and more to provide more accurate battery and environmental data for warranty with battery manufacturer's claims.

## **10. DRAWINGS/SCHEMATICS**

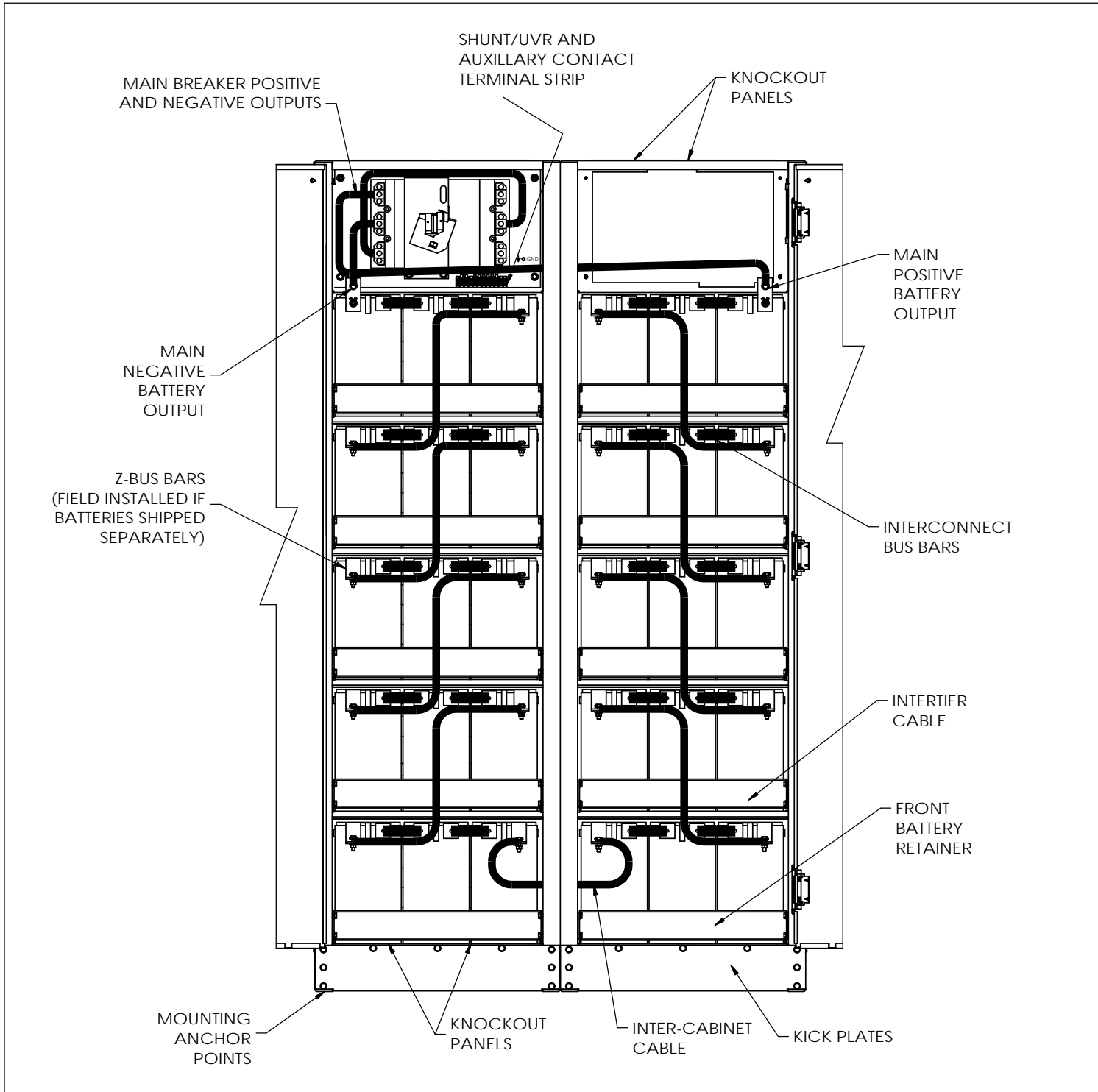

STANDARD CABLING OPTION

TITLE: MANUAL DRAWING, 16HX BATTERY CABINETS  
GENERAL VIEWS

DWG. NO.

DOC-013400

REV  
A



	NAME	DATE
DRAWN	RNA	01-11-16
APPR.		



FRONT VIEW

SIDE VIEW

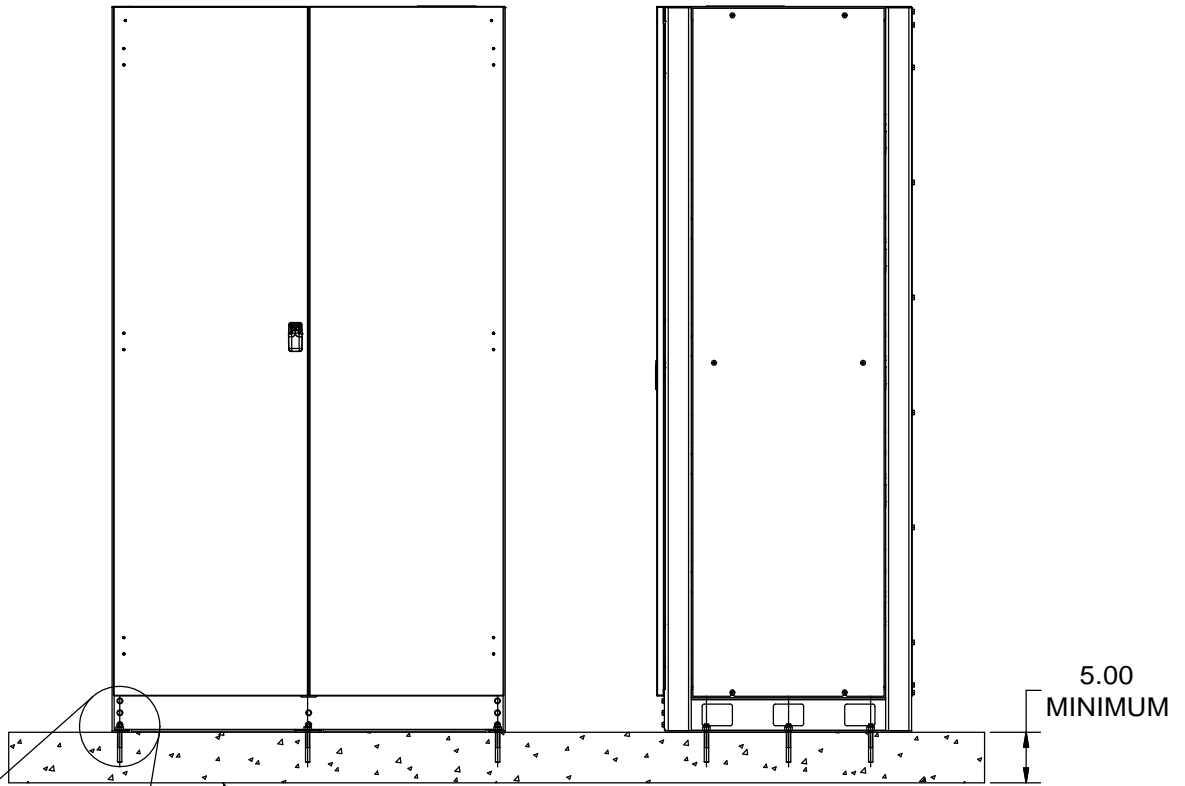

CONCRETE FLOOR  
MIN. 2000 PSI

5.00  
MINIMUM

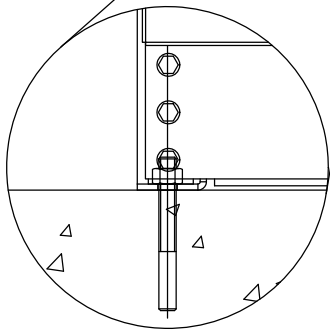

1/2" DIA. HILTI KB-II EXPANSION ANCHORS  
PER ER-4627

THE BATTERY CABINETS HAVE BEEN CERTIFIED TO THE IBC 2012, SECTION 1621 & 1622. CABINET MUST BE ANCHORED WITH 6 HILTI KB-II EXPANSION BOLTS OR EQUIVALENT. CHECK APPLICABLE BUILDING CODES FOR LENGTH AND STYLE OF ANCHORS TO BE USED WITH FLOORING SUBSTRATE. INSTALL ANCHORS PER MANUFACTURER'S INSTRUCTIONS. THIS DRAWING IS A STANDARD REPRESENTATION. CABINET CONFIGURATIONS WILL VARY. 3 ANCHORS PER RAIL AS SHOWN ABOVE.

TITLE: MANUAL DRAWING, 16HX BATTERY CABINETS  
SEISMIC ANCHORING

DWG. NO.

DOC-013500

REV  
A



	NAME	DATE
DRAWN	RNA	01-11-16
APPR.		
SHEET 1 OF 3		



CABLE ENTRY PLATES  
8.0 X 3.0 CUTOUTS, 4X

Ø.56  
TYP.

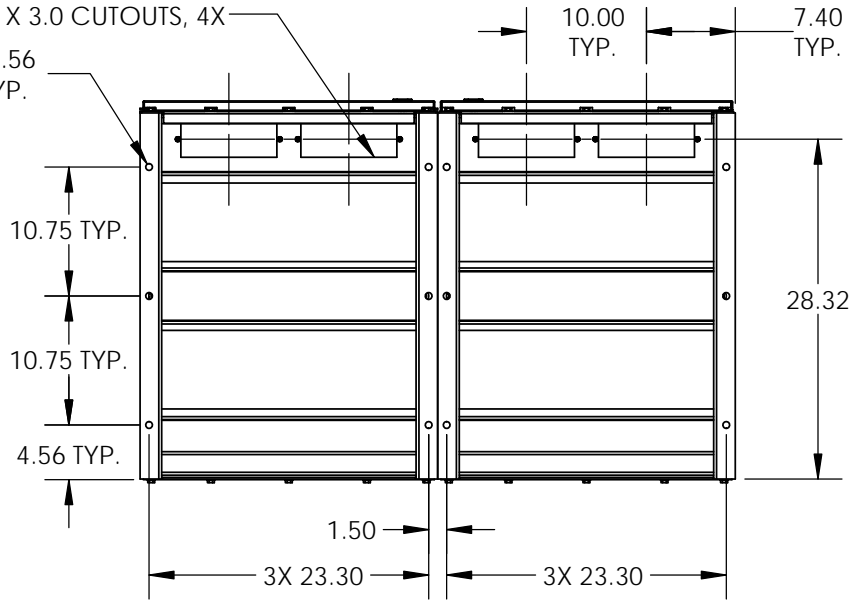

EFC5A FOOT PRINT

30 BLOCKS, 480V  
24 BLOCKS, 384V

EFC4A FOOT PRINT

24 BLOCKS, 384V  
18 BLOCKS, 288V

CABLE ENTRY PLATES  
8.0 X 3.0 CUTOUTS, 2X

NO KNOCKOUTS  
THESE TWO LOCATIONS

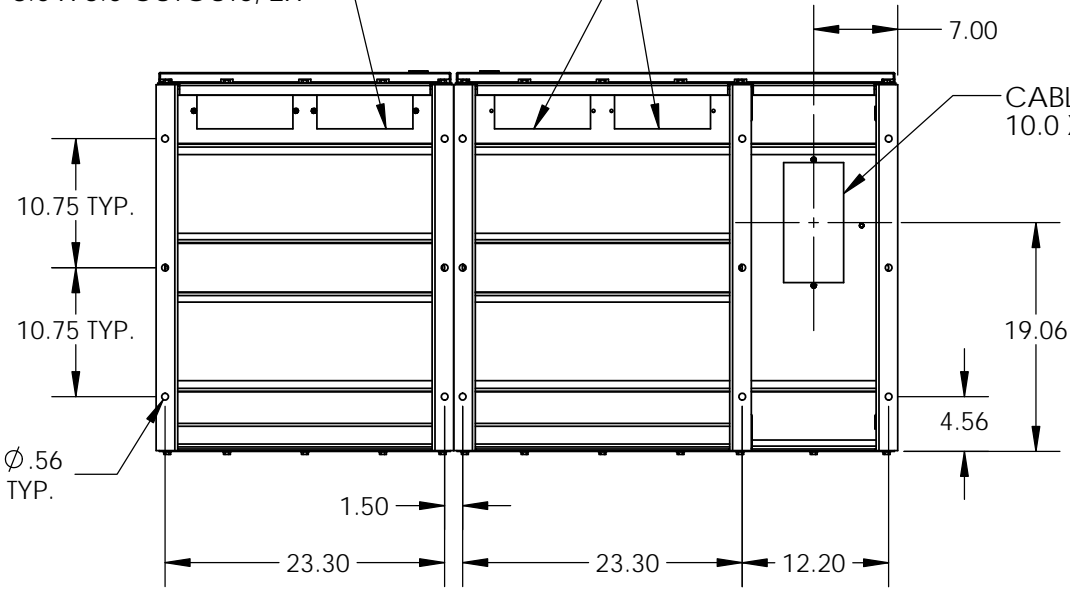

EFS5A FOOT PRINT

30 BLOCKS, 480V  
24 BLOCKS, 384V

TITLE: MANUAL DRAWING, 16HX BATTERY CABINETS  
SEISMIC ANCHORING



	NAME	DATE
DRAWN	RNA	01-11-16
APPR.		
SHEET 2 OF 3		

DWG. NO. DOC-013500 REV A

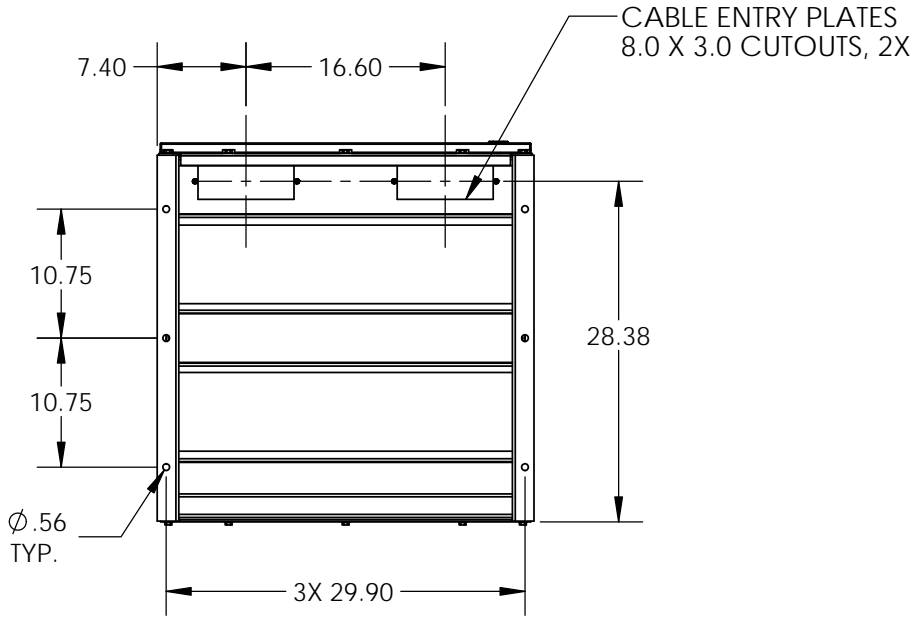

EFC5B FOOT PRINT

30 BLOCKS, 480V  
24 BLOCKS, 384V

EFC4B FOOT PRINT

24 BLOCKS, 384V  
18 BLOCKS, 288V

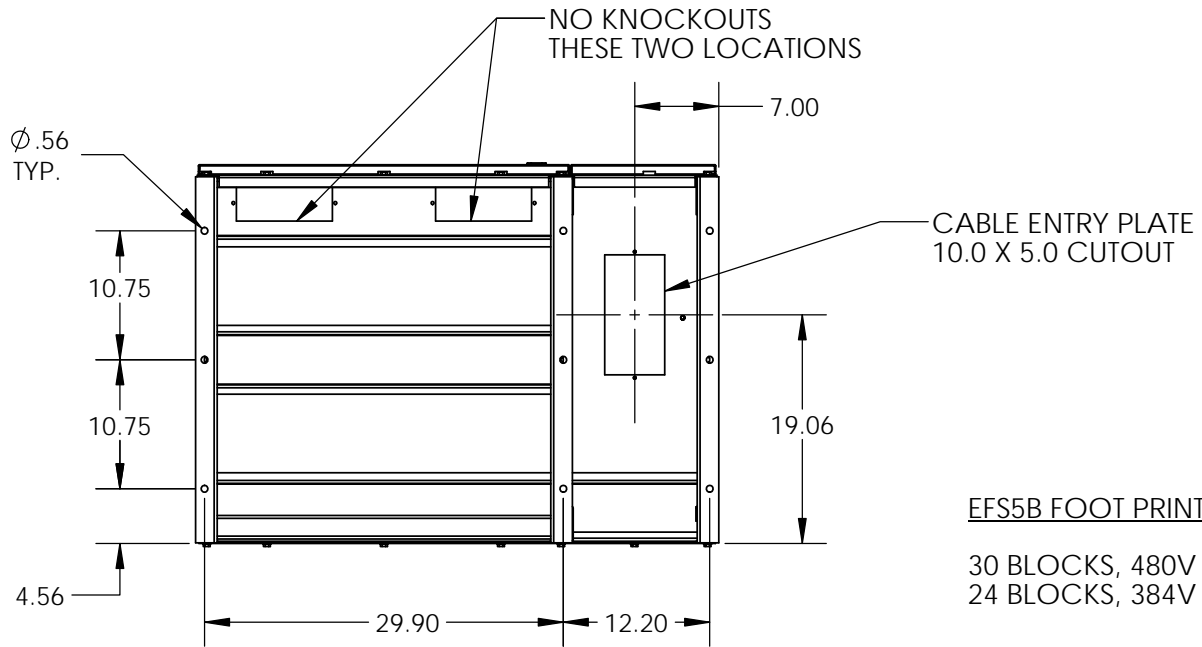

EFS5B FOOT PRINT

30 BLOCKS, 480V  
24 BLOCKS, 384V

TITLE: MANUAL DRAWING, 16HX BATTERY CABINETS  
SEISMIC ANCHORING

DWG. NO.

DOC-013500

REV  
A

	NAME	DATE
DRAWN	RNA	01-11-16
APPR.		
SHEET 3 OF 3		



- NOTES:
1. NEMA 1 DESIGN
  2. EMPTY CABINET WEIGHT: 750 LBS (340 KG)
  3. SEE TABLE FOR LOADED WEIGHTS

BATTERY CABINET LOADED WEIGHTS		
MFG	BATTERY MODEL	WEIGHT(LBS)
ENERSYS	16HX925F-FR	8290
	16HX800F-FR	7810

### BREAKER DETAIL

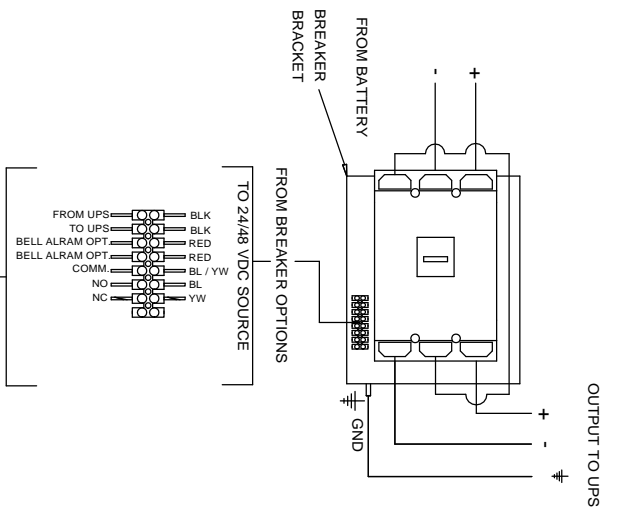

AUXILIARY CONTACTS LISTED APPLICABLE WHEN BREAKER IS IN THE CLOSED (ON) POSITION

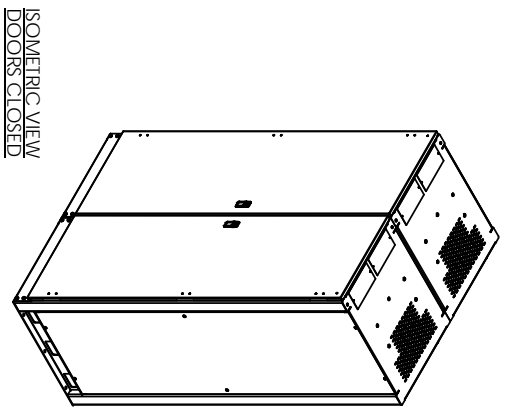

ISOMETRIC VIEW  
DOORS CLOSED

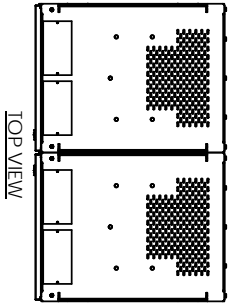

TOP VIEW

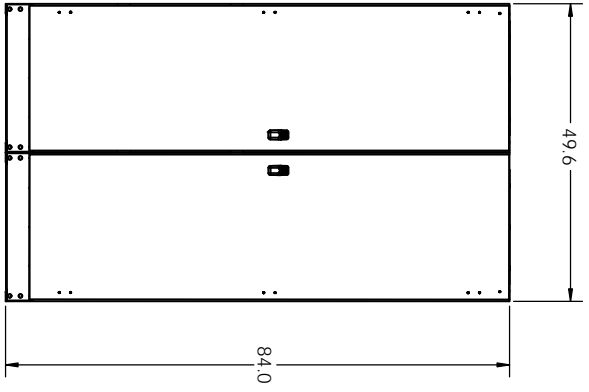

FRONT VIEW

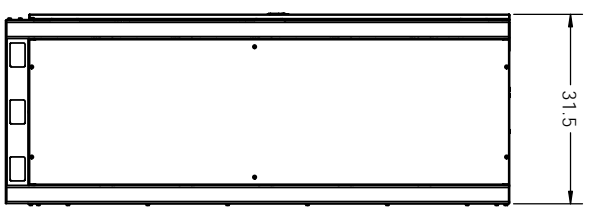

SIDE VIEW

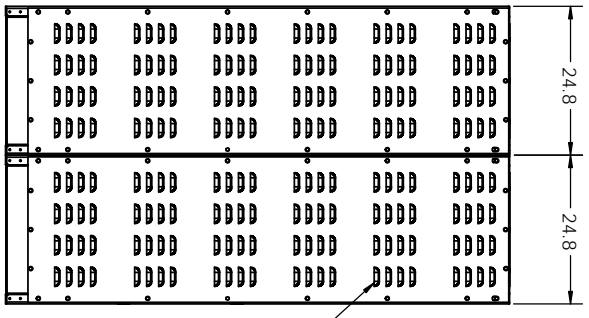

REAR VIEW

VENTILATION  
LOUVERS

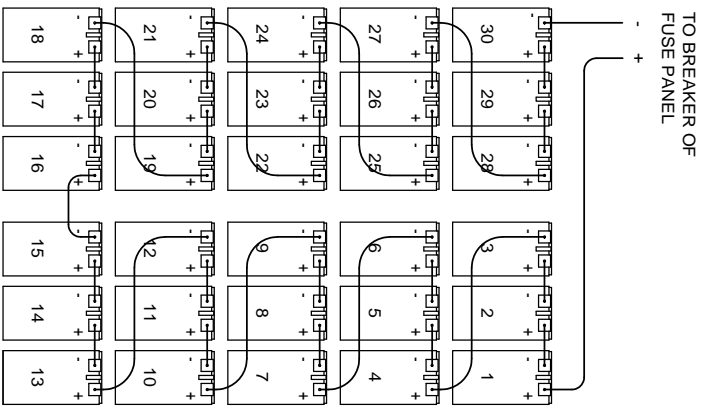

PROHIBITARY AND COMMERCIAL

THE INFORMATION CONTAINED IN THIS DRAWING IS THE PROPERTY OF ESS. IT IS TO BE USED FOR THE PROJECT AND SITE SPECIFICALLY IDENTIFIED HEREIN. ANY REUSE OR DISTRIBUTION OF THIS INFORMATION WITHOUT THE WRITTEN PERMISSION OF ESS IS STRICTLY PROHIBITED.

ESS ELECTRONIC SYSTEMS SUPPORT www.ess.io	3233 W. Kingsley Rd. Garland, Texas 75041 PH: 972-272-2468 FAX: 972-276-9848
NAME: EC58A BATTERY CABINET, 480V, TOP BRKR, 30 BLOC'S	DATE: 1/17/17
DRAWN: RNU	DATE: 1/17/17
APPR: RVA	DATE: 1/17/17
UNLESS OTHERWISE SPECIFIED, DIMENSIONS ARE IN INCHES	DWG. NO. DOC-013600
PROJECTION:	REV: A
DO NOT SCALE DRAWING	SHEET 1 OF 1





- NOTES:
1. NEMA 1 DESIGN
  2. EMPTY CABINET WEIGHT: 750 LBS (340 KG)
  3. SEE TABLE FOR LOADED WEIGHTS

BATTERY CABINET LOADED WEIGHTS		
MFG	BATTERY MODEL	WEIGHT (LBS)
ENERSYS	16HX925F-FR	6802
	16HX800F-FR	6418

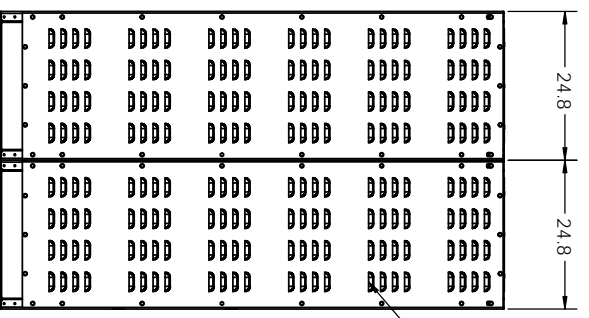
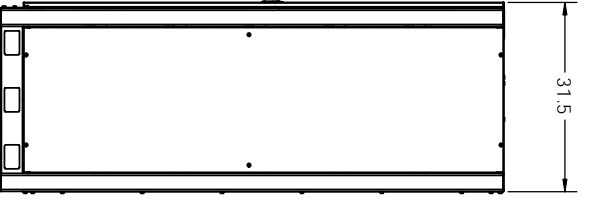
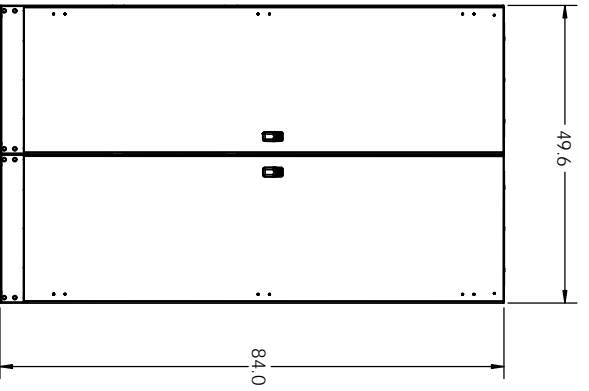
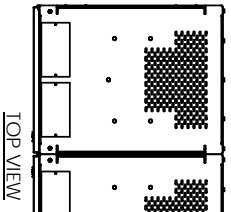

**BREAKER DETAIL**

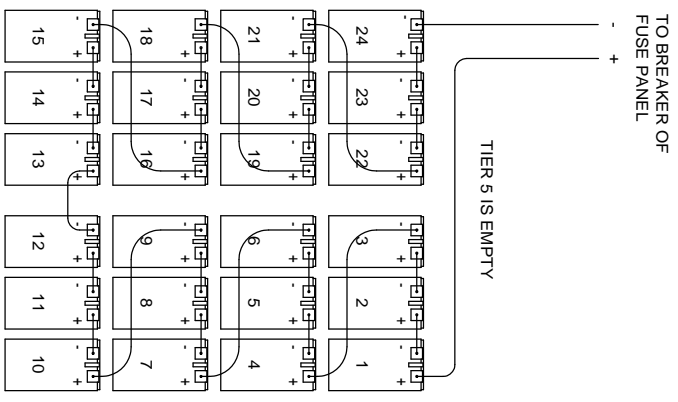
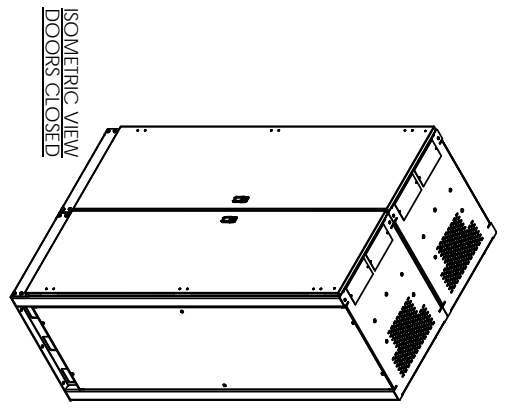
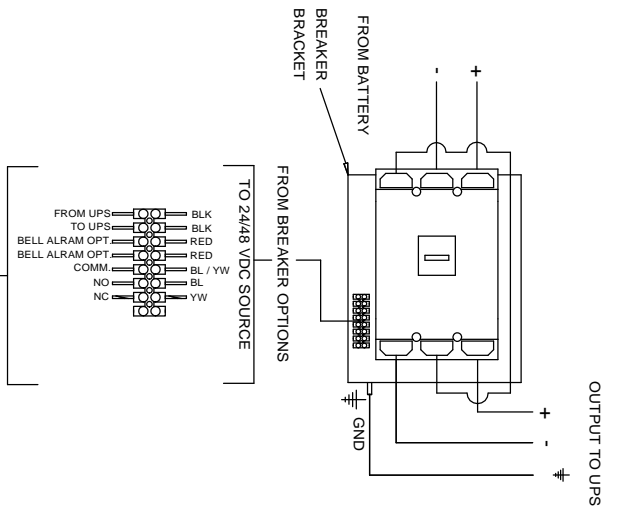

VENTILATION LOUVERS

PROHIBITARY AND COMMERCIAL  
THE REPRODUCTION OR TRANSMISSION OF THIS DOCUMENT IN ANY MANNER WITHOUT THE WRITTEN PERMISSION OF ENERSYS IS PROHIBITED.

ESS ELECTRONIC SYSTEMS SUPPORT  
www.ess.io

3233 W. Kingsley Rd  
Garland, Texas 75041  
PH: 972-272-2468  
FAX: 972-278-9848

DATE:	1/17/17	TITLE:	EC5A BATTERY CABINET,
APPR:	RNA	DWG. NO.:	384V, TOP BRKR, 24 BLOCs
DESIGNED BY:	RNA	DOC. NO.:	DOC-013700
REVISIONS:		REV.:	A

PROJECTION: DO NOT SCALE DRAWING. SHEET 1 OF 1



- NOTES:
1. NEMA 1 DESIGN
  2. EMPTY CABINET WEIGHT: 640 LBS (291 KG)
  3. SEE TABLE FOR LOADED WEIGHTS

BATTERY CABINET LOADED WEIGHTS		
MFG	BATTERY MODEL	WEIGHT(LBS)
ENERSYS	16HX925F-FR	6692
	16HX800F-FR	6308

**BREAKER DETAIL**

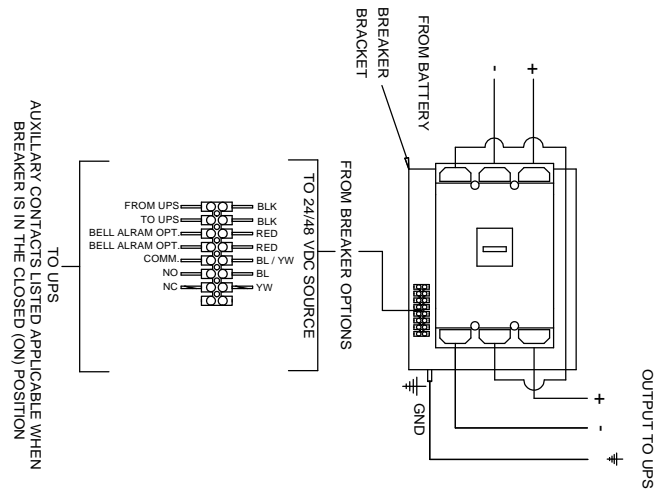

**ISOMETRIC VIEW  
DOORS CLOSED**

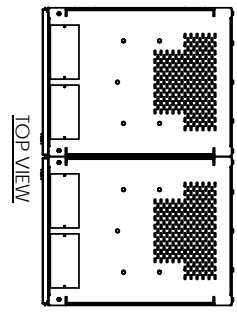
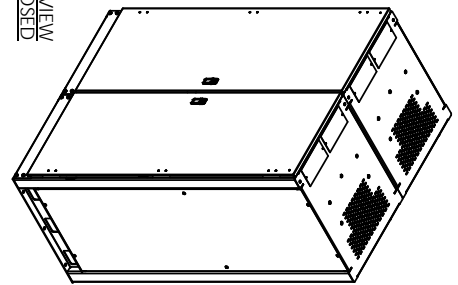

TOP VIEW

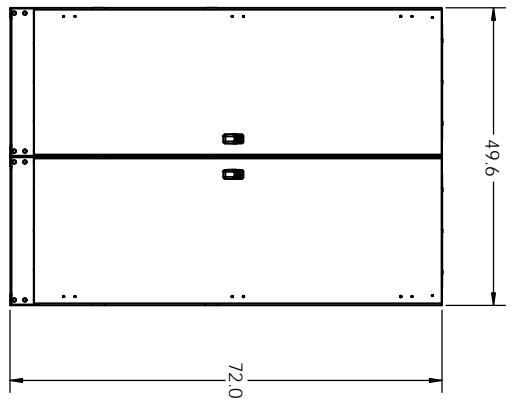

FRONT VIEW

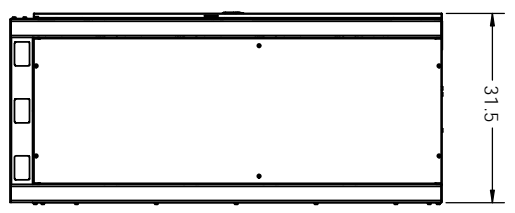

SIDE VIEW

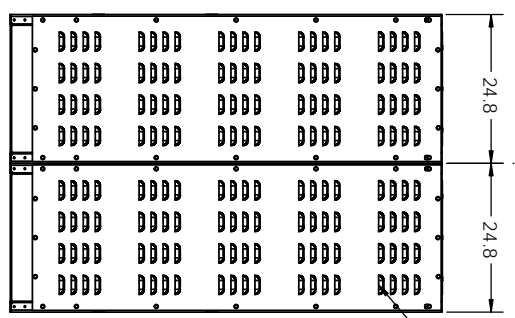

REAR VIEW

VENTILATION LOUVERS

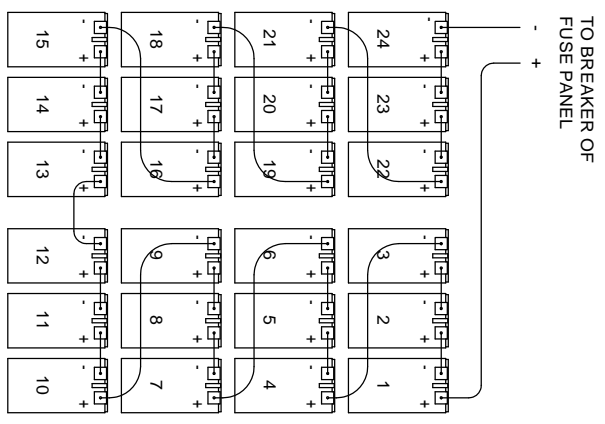

TO BREAKER OF  
FUSE PANEL

**PROHIBITARY AND CONFIDENTIAL**

THE INFORMATION CONTAINED IN THIS DOCUMENT IS UNCLASSIFIED EXCEPT WHERE SHOWN OTHERWISE. ANY USE OF THIS INFORMATION IS AT THE USER'S RISK.

**ESS ELECTRONIC SYSTEMS SUPPORT**  
www.ess.io

3233 W. Kingsley Rd.  
Garland, Texas 75041  
PH: 972-272-2468  
FAX: 972-278-9844

NAME	DATE	TITLE
RNAJ	1/17/17	ESS C4A BATTERY CABINET, 384V, TOP BRKR, 24 BLOCs
RNAJ	1/17/17	UNLESS OTHERWISE SPECIFIED, DIMENSIONS ARE IN INCHES
DWG. NO.	DOC. NO.	REV
	DOC-013800	A

PROJECTION: DO NOT SCALE DRAWING. SHEET 1 OF 1

- NOTES:
1. NEMA 1 DESIGN
  2. EMPTY CABINET WEIGHT: 640 LBS (291 KG)
  3. SEE TABLE FOR LOADED WEIGHTS

BATTERY CABINET LOADED WEIGHTS		
MFG	BATTERY MODEL	WEIGHT(LBS)
ENERSYS	16HX925F-FR	5204
	16HX800F-FR	4916

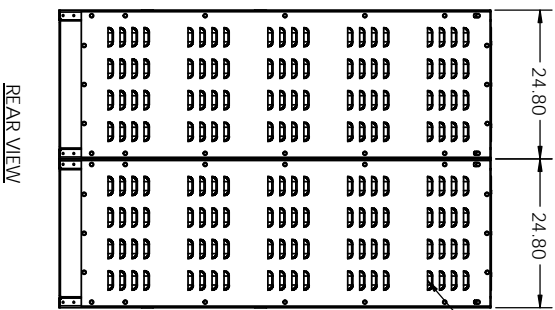
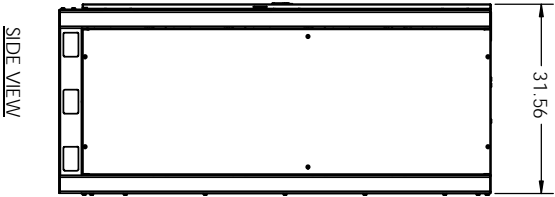
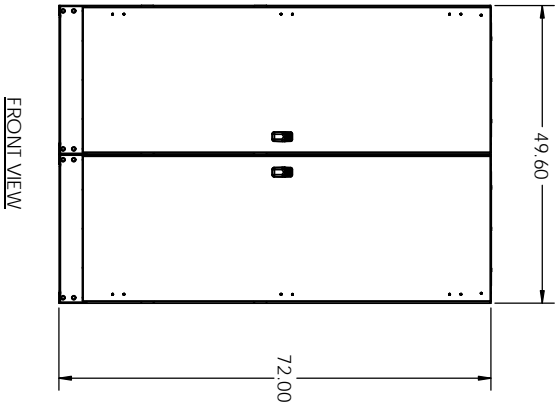
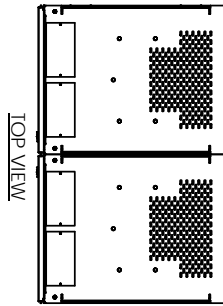

### BREAKER DETAIL

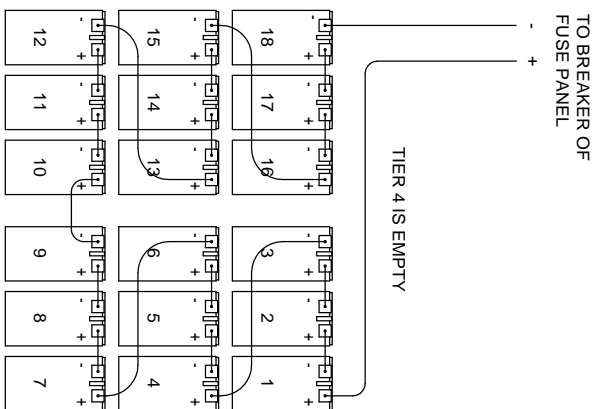
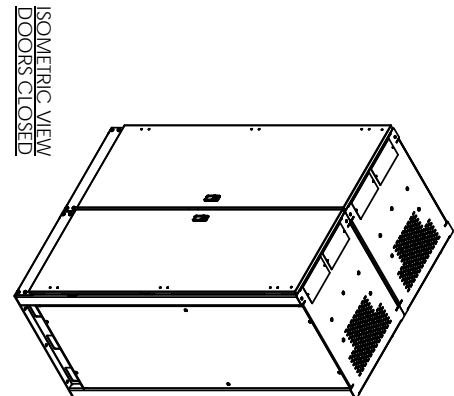
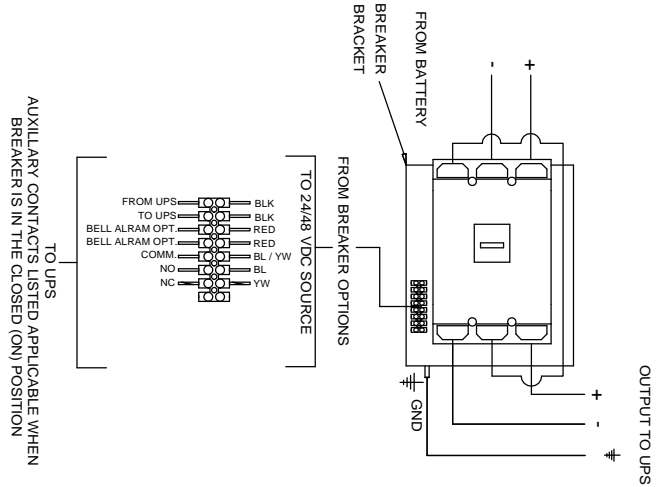

PROHIBITARY AND CONFIDENTIAL

THE INFORMATION CONTAINED IN THIS DRAWING IS UNCLASSIFIED EXCEPT WHERE SHOWN OTHERWISE AND IS NOT TO BE REPRODUCED, COPIED, OR TRANSMITTED IN ANY FORM OR BY ANY MEANS, ELECTRONIC OR MECHANICAL, WITHOUT THE WRITTEN PERMISSION OF THE ISSUING OFFICE.

DATE:	1/17/17	TITLE:	3233 W. Kingsley Rd. Garland, Texas 75041 PH: 972-272-2468 FAX: 972-278-9844
NAME:	RNA	DWG. NO.:	288AV, TOP BRKR, 18 BLOC'S
DATE:	1/17/17	DOC. NO.:	DOC-013900
APPR.:	RNA	REV.:	A
UNLESS OTHERWISE SPECIFIED, DIMENSIONS ARE IN INCHES.			

PROJECTION: DO NOT SCALE DRAWING. SHEET 1 OF 1



- NOTES:
1. NEMA 1 DESIGN
  2. EMPTY CABINET WEIGHT: 840 LBS (381 KG)
  3. SEE TABLE FOR LOADED WEIGHTS

BATTERY CABINET LOADED WEIGHTS		
MFG	BATTERY MODEL	WEIGHT(LBS)
ENERSYS	16HX925F-FR	8380
	16HX800F-FR	7900

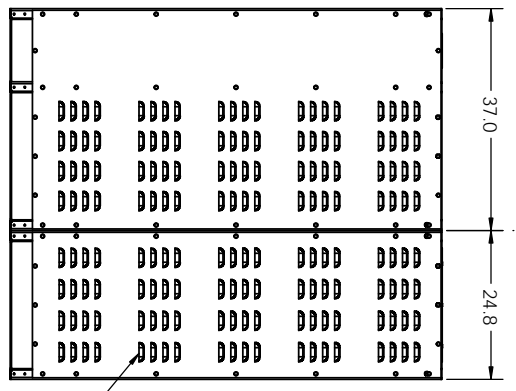
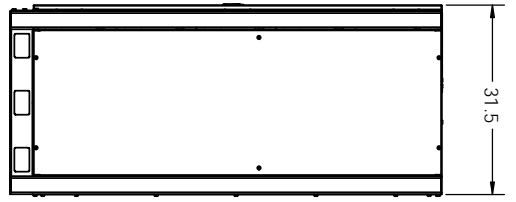
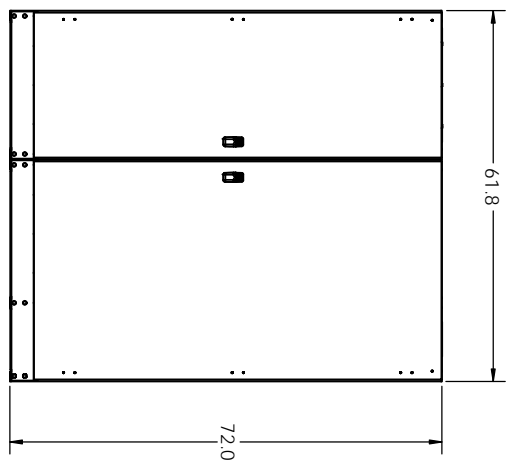
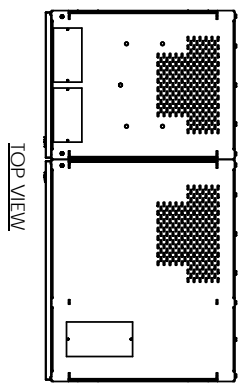

**BREAKER DETAIL**

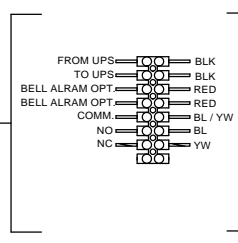
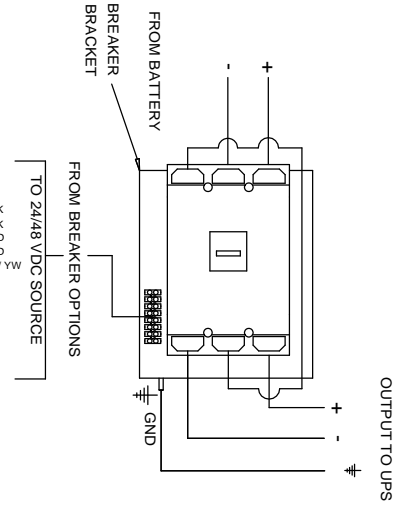

AUXILIARY CONTACTS LISTED APPLICABLE WHEN BREAKER IS IN THE CLOSED (ON) POSITION

**ISOMETRIC VIEW DOORS CLOSED**

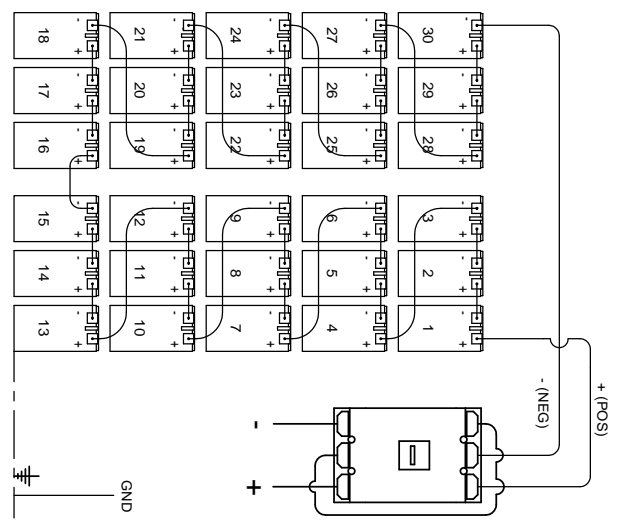
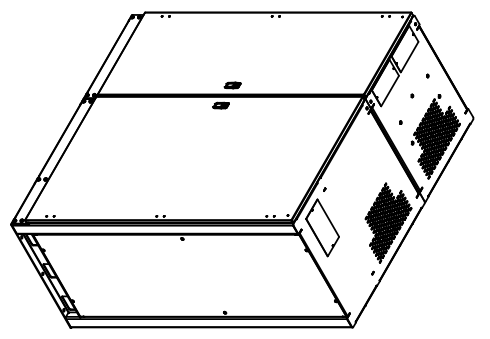

**VENTILATION LOUVERS**

PROHIBITARY AND COMMERCIAL

THE INFORMATION CONTAINED IN THIS DOCUMENT IS UNCLASSIFIED EXCEPT WHERE SHOWN OTHERWISE. THIS INFORMATION IS UNCLASSIFIED EXCEPT WHERE SHOWN OTHERWISE.

ESS ELECTRONIC SYSTEMS SUPPORT  
www.ess.io

3233 W. Kingsley Rd.  
Garland, Texas 75041  
PH: 972-272-2468  
FAX: 972-276-9844

DATE:	1/17/17	TITLE:	ESS5A BATTERY CABINET, 480V, SIDE BRKR, 30 BLOCs
DESIGNER:	RNA	DATE:	1/17/17
APPROVER:	RNA	DATE:	1/17/17
UNLESS OTHERWISE SPECIFIED, DIMENSIONS ARE IN INCHES		DWG. NO.	DOC-014000
PROJECTION:		DO NOT SCALE DRAWING:	SHEET 1 OF 1



- NOTES:
1. NEMA 1 DESIGN
  2. EMPTY CABINET WEIGHT: 840 LBS (381 KG)
  3. SEE TABLE FOR LOADED WEIGHTS

BATTERY CABINET LOADED WEIGHTS		
MFG	BATTERY MODEL	WEIGHT(LBS)
EMERSON	16HX925F-FR	6892
	16HX800F-FR	6508

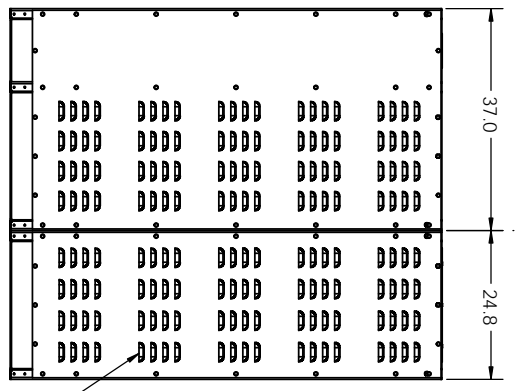
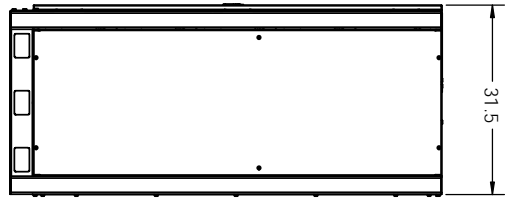
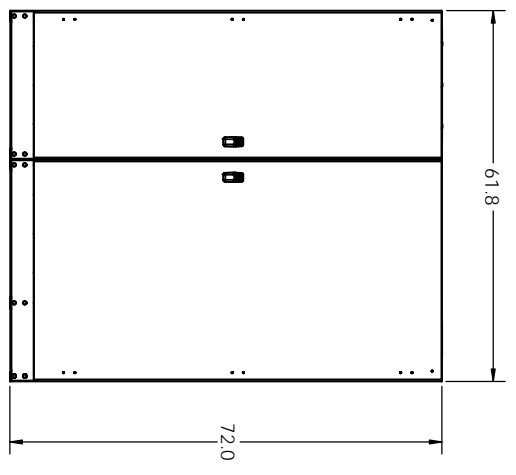
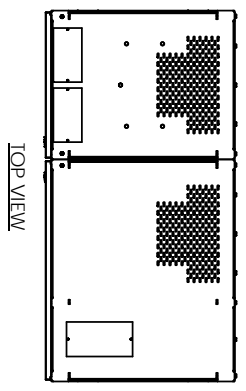

### BREAKER DETAIL

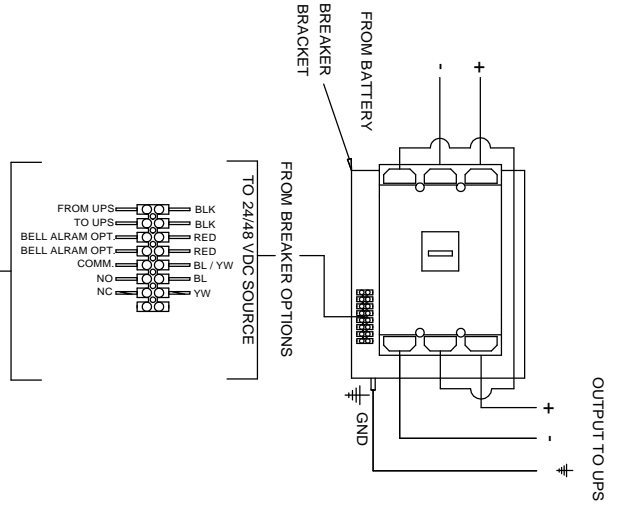

AUXILIARY CONTACTS LISTED APPLICABLE WHEN BREAKER IS IN THE CLOSED (ON) POSITION

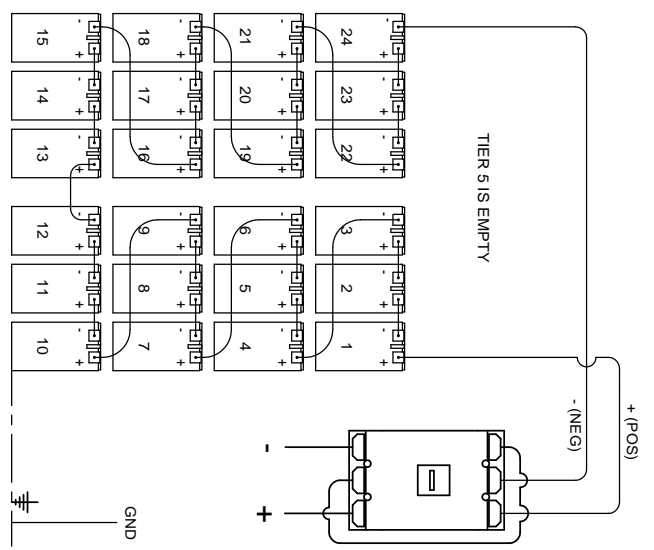
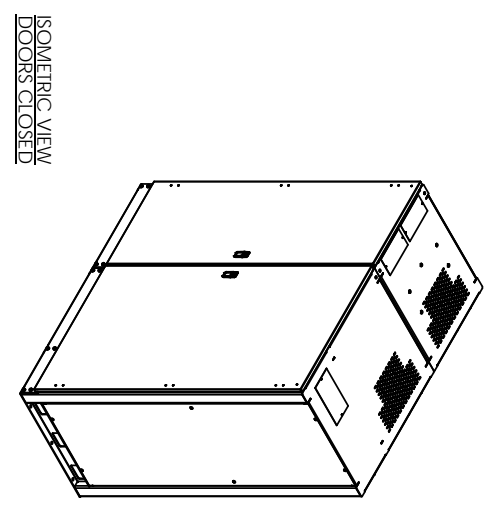

### VENTILATION LOUVERS

PROHIBITARY AND COMMERCIAL

THE INFORMATION CONTAINED IN THIS DOCUMENT IS UNCLASSIFIED EXCEPT WHERE SHOWN OTHERWISE. ANY USE OF THIS INFORMATION IS AT THE USER'S RISK. THE INFORMATION IS NOT TO BE REPRODUCED OR TRANSMITTED IN ANY FORM OR BY ANY MEANS, ELECTRONIC OR MECHANICAL, INCLUDING PHOTOCOPYING, RECORDING, OR BY ANY INFORMATION STORAGE AND RETRIEVAL SYSTEM.

ESS ELECTRONIC SYSTEMS SUPPORT  
www.ess.io

3233 W. Kingsley Rd.  
Garland, Texas 75041  
PH: 972-272-2468  
FAX: 972-276-9844

DATE	TITLE
1/17/17	ESS5A BATTERY CABINET,
1/17/17	384V, SIDE BRKR, 24 BLOCs

REVISIONS

NO.	DATE	DESCRIPTION
1	1/17/17	ISSUES CHANGES SPECIFIED
2	1/17/17	DIMENSIONS ARE IN INCHES

PROJECTION: DO NOT SCALE DRAWING

SHEET 1 OF 1



- NOTES:
1. NEMA 1 DESIGN
  2. EMPTY CABINET WEIGHT: 550 LBS (250 KG)
  3. SEE TABLE FOR LOADED WEIGHTS

BATTERY CABINET LOADED WEIGHTS		
MFG	BATTERY MODEL	WEIGHT(LBS)
ENERSYS	16HX550F-FR	5180

### BREAKER DETAIL

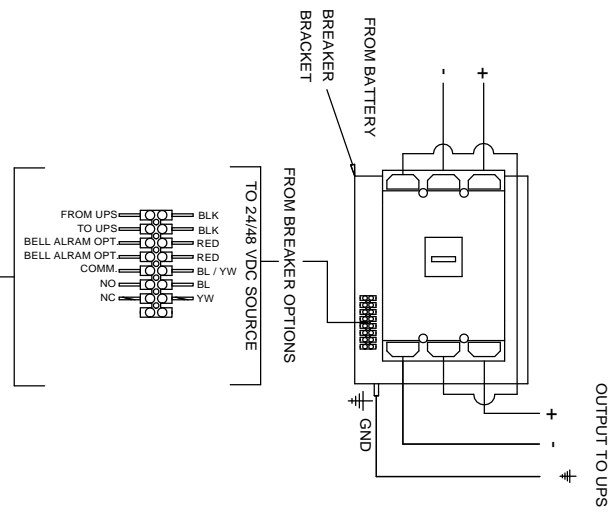

AUXILIARY CONTACTS LISTED APPLICABLE WHEN BREAKER IS IN THE CLOSED (ON) POSITION

### ISOMETRIC VIEW DOORS CLOSED

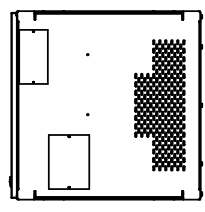
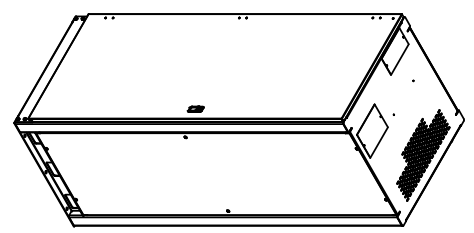

TOP VIEW

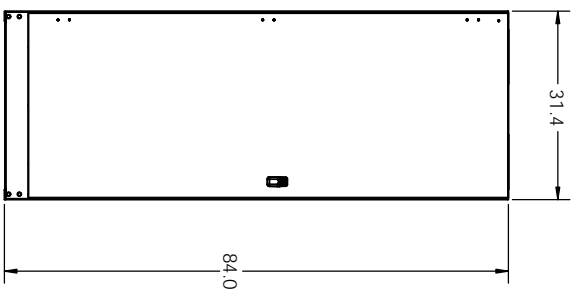

FRONT VIEW

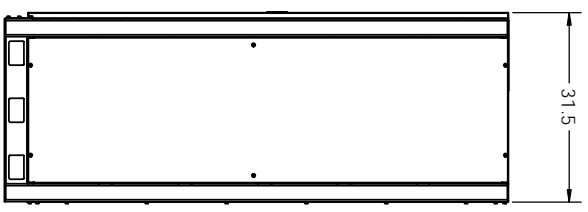

SIDE VIEW

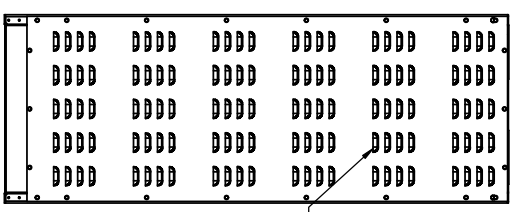

REAR VIEW

VENTILATION LOUVERS

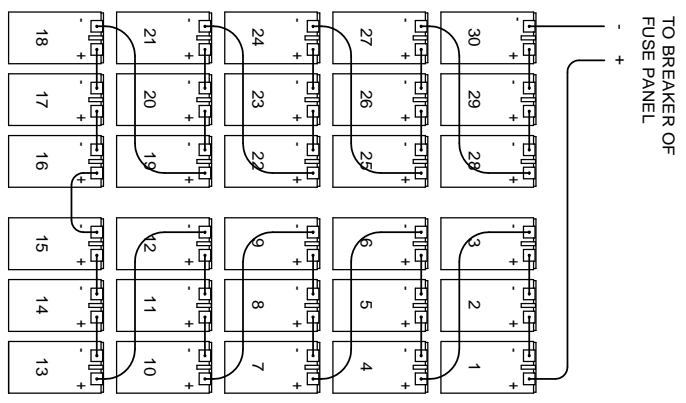

**PROHIBITARY AND CONFIDENTIAL**

THE INFORMATION CONTAINED IN THIS DRAWING IS UNCLASSIFIED EXCEPT WHERE SHOWN OTHERWISE. ANY REPRODUCTION OR TRANSMISSION OF THIS INFORMATION WITHOUT THE WRITTEN PERMISSION OF ENERSYS IS PROHIBITED.

NAME	DATE	TITLE	3233 W. Kingsley Rd. Garland, Texas 75041 PH: 972-272-2468 WWW.ESS.CO
DRW/N	RJW 1/7/17	EC58B BATTERY CABINET, 480V, TOP BRKR, 30 BLOCs	
APPR	RVA 1/7/17	UNLESS OTHERWISE SPECIFIED, DIMENSIONS ARE IN INCHES	
PROJ		DWG. NO. DOC-014200	
REV			

PROJECTION: DO NOT SCALE DRAWING. SHEET 1 OF 1



- NOTES:
1. NEMA 1 DESIGN
  2. EMPTY CABINET WEIGHT: 550 LBS (250 KG)
  3. SEE TABLE FOR LOADED WEIGHTS

BATTERY CABINET LOADED WEIGHTS		
MFG	BATTERY MODEL	WEIGHT(LBS)
ENERSYS	16HX500-FR	4274

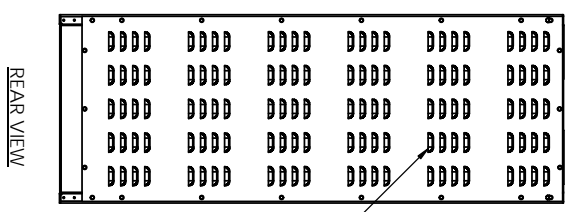
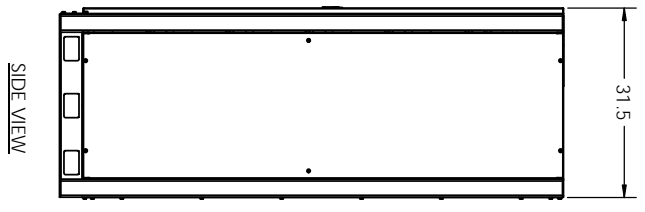
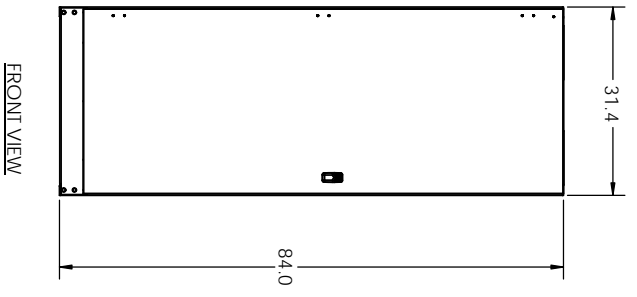
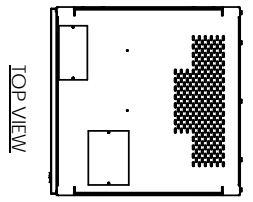

### BREAKER DETAIL

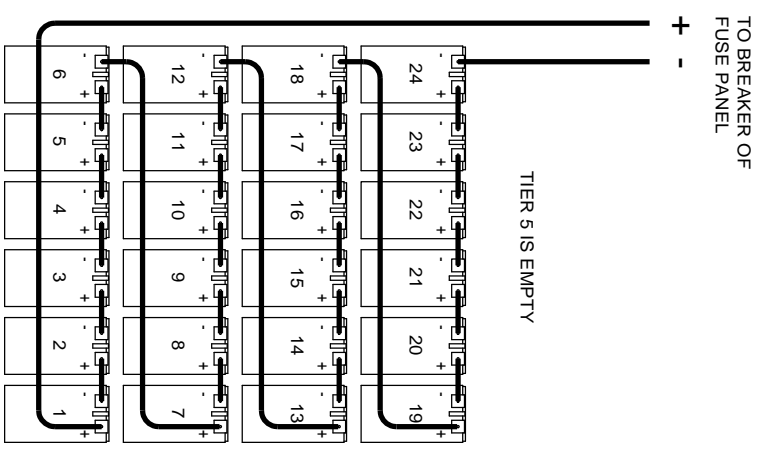
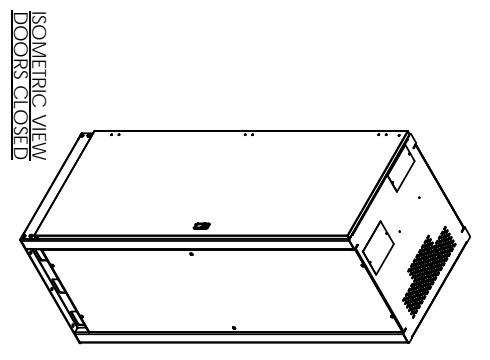
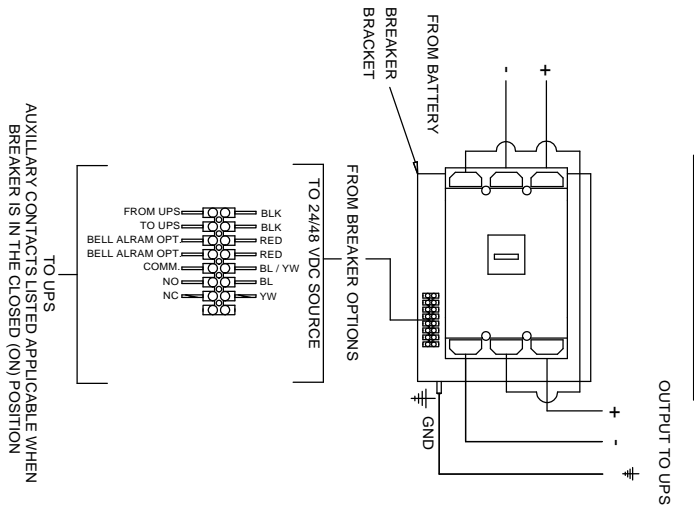

**PROHIBITARY AND CONFIDENTIAL**

THE INFORMATION CONTAINED IN THIS DRAWING IS UNCLASSIFIED EXCEPT WHERE SHOWN OTHERWISE. ANY REPRODUCTION OR TRANSMISSION OF THIS INFORMATION IS PROHIBITED WITHOUT THE WRITTEN PERMISSION OF ELECTRONIC SYSTEMS SUPPORT.

DATE:	1/17/17	TITLE:	384V, TOP BRKR, 24 BLOC'S
NAME:	RNU	DWG. NO.:	DOC-014300
DATE:	1/17/17	REV:	A
NAME:	RNA	PROJECTION:	DO NOT SCALE DRAWING
DATE:	1/17/17	SHEET:	1 OF 1

**ESS ELECTRONIC SYSTEMS SUPPORT**  
www.ess.io

3233 W. Kingsley Rd.  
Garland, Texas 75041  
PH: 972-272-2468  
FAX: 972-276-9844



- NOTES:
1. NEMA 1 DESIGN
  2. EMPTY CABINET WEIGHT: 490 LBS (222 KG)
  3. SEE TABLE FOR LOADED WEIGHTS

BATTERY CABINET LOADED WEIGHTS		
MFG	BATTERY MODEL	WEIGHT(LBS)
ENERSYS	16HX550F-FR	4214

### BREAKER DETAIL

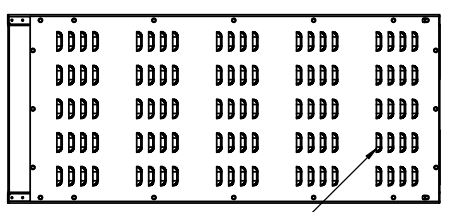
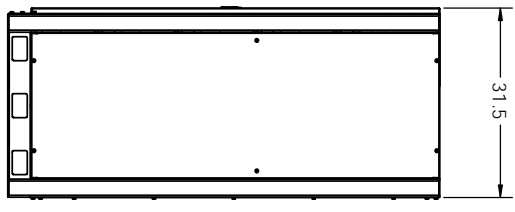
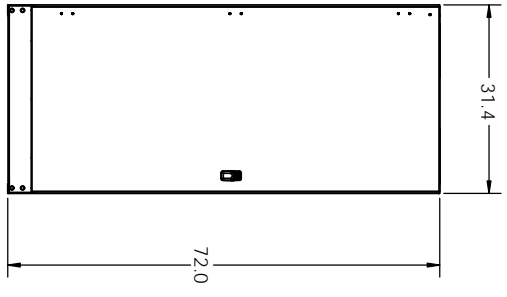
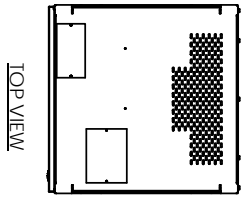
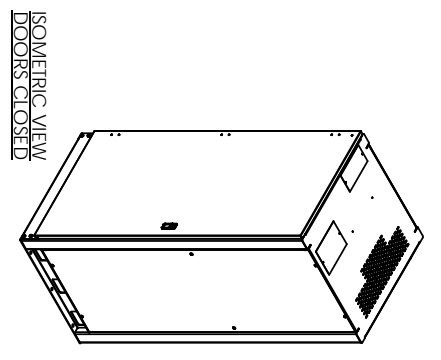
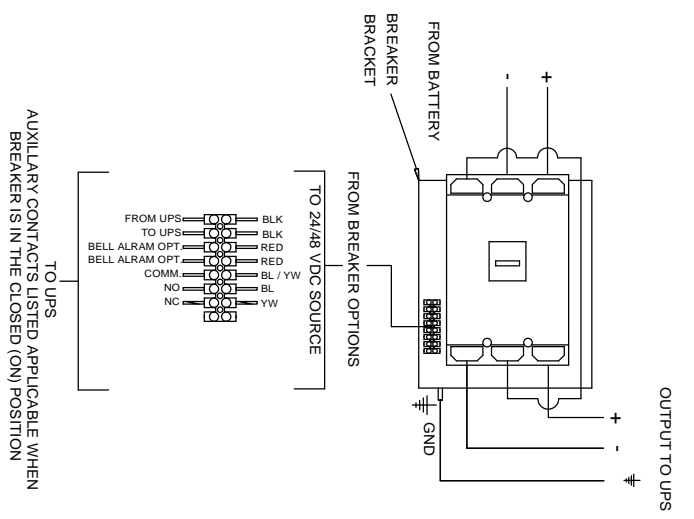

### TO BREAKER OF FUSE PANEL

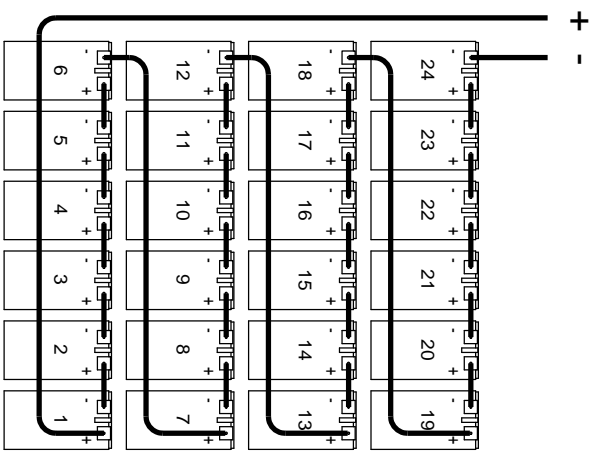

**PROHIBITARY AND CONFIDENTIAL**  
THE INFORMATION CONTAINED IN THIS DRAWING IS THE PROPERTY OF ESS. IT IS TO BE USED FOR THE PROJECT AND SITE SPECIFICALLY IDENTIFIED HEREIN. ANY REUSE OR DISSEMINATION OF THIS INFORMATION WITHOUT THE WRITTEN PERMISSION OF ESS IS PROHIBITED.

**ESS ELECTRONIC SYSTEMS SUPPORT**  
www.ess.io

3233 W. Kingsley Rd.  
Garland, Texas 75041  
PH: 972-272-2468  
FAX: 972-276-9844

NAME:	DATE:	TITLE:
REV:	1/17/17	EFCAB BATTERY CABINET,
APPR:	1/17/17	UNLESS OTHERWISE SPECIFIED,
		DIMENSIONS ARE IN INCHES
DWG. NO:	384V, TOP BRKR, 24 BLOCs	REV:
DOC. NO:	DOC-014400	A

PROJECTION: DO NOT SCALE DRAWING. SHEET 1 OF 1





- NOTES:
1. NEMA 1 DESIGN
  2. EMPTY CABINET WEIGHT: 490 LBS (222 KG)
  3. SEE TABLE FOR LOADED WEIGHTS

BATTERY CABINET LOADED WEIGHTS		
MFG	BATTERY MODEL	WEIGHT(LBS)
ENERSYS	16HX50F-FR	3308

**BREAKER DETAIL**

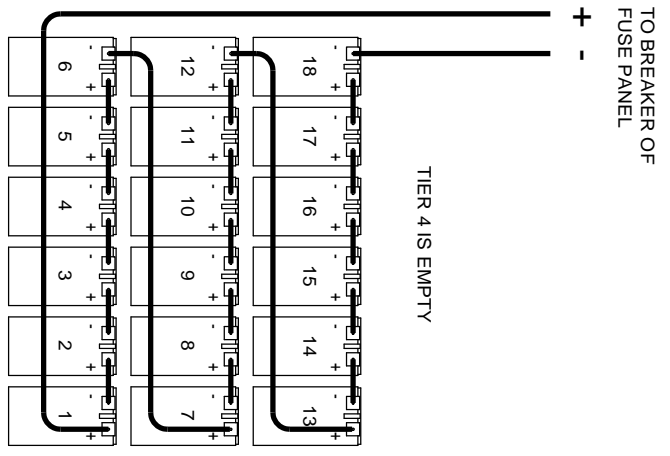
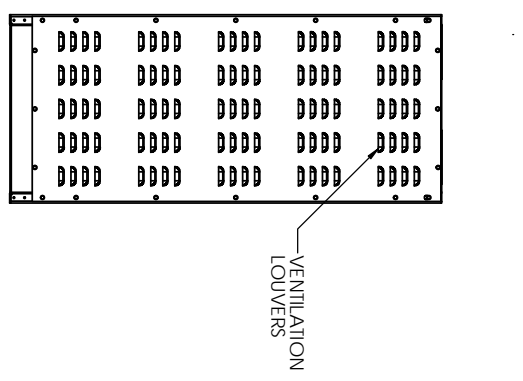
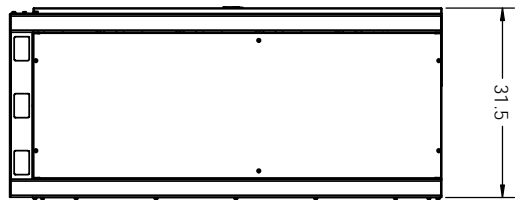
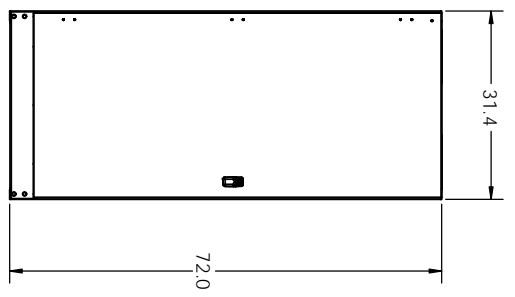
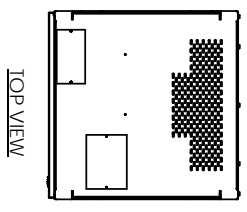
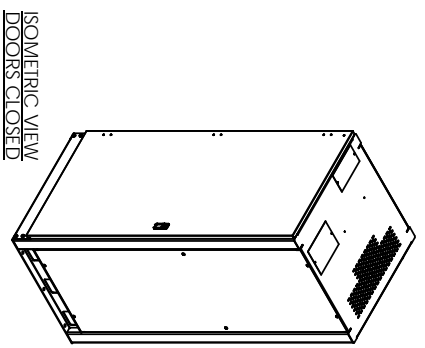
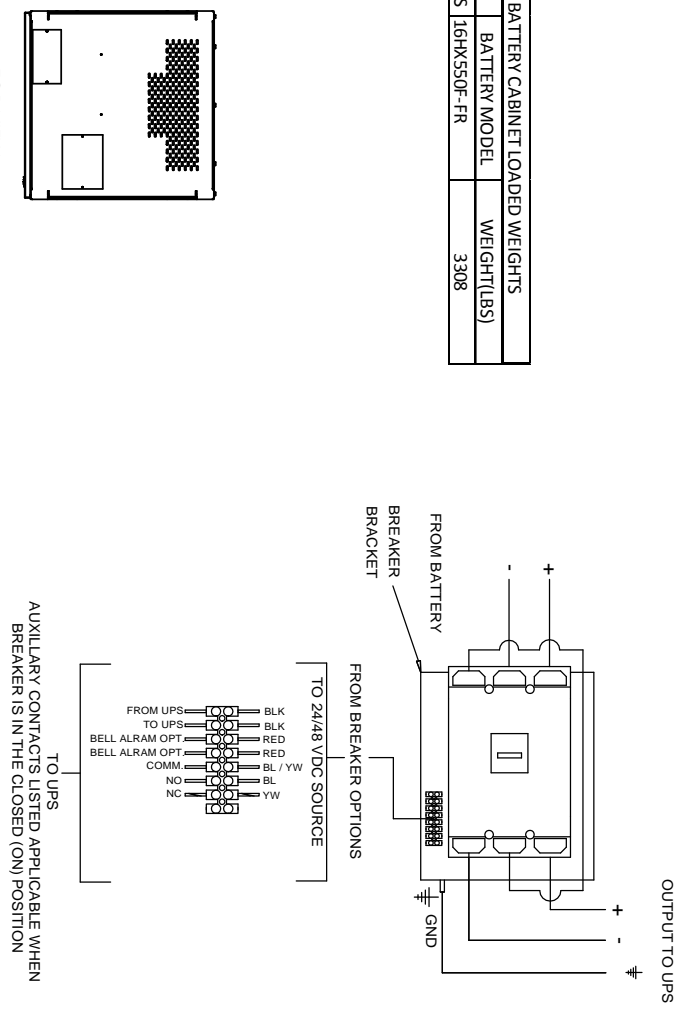

PROHIBITARY AND COMMERCIAL  
THE INFORMATION CONTAINED IN THIS DRAWING IS THE PROPERTY OF ESS ELECTRONIC SYSTEMS SUPPORT. ANY REPRODUCTION OR TRANSMISSION OF THIS INFORMATION WITHOUT THE WRITTEN PERMISSION OF ESS ELECTRONIC SYSTEMS SUPPORT IS PROHIBITED.

NAME	DATE	TITLE
RNAJ	1/17/17	ESS CAB BATTERY CABINET, 288V, TOP BRKR, 18 BLOC'S
RNAJ	1/17/17	

UNLESS OTHERWISE SPECIFIED, DIMENSIONS ARE IN INCHES

PROJECTION: DO NOT SCALE DRAWING. SHEET 1 OF 1

3233 W. Kingsley Rd.  
Garland, Texas 75041  
PH: 972-272-2468  
FAX: 972-276-9844  
www.ess.io



- NOTES:
1. NEMA 1 DESIGN
  2. EMPTY CABINET WEIGHT: 620 LBS (282 KG)
  3. SEE TABLE FOR LOADED WEIGHTS

BATTERY CABINET LOADED WEIGHTS		
MFG	BATTERY MODEL	WEIGHT(LBS)
ENERSYS	16HX50F-FR	5250

**BREAKER DETAIL**

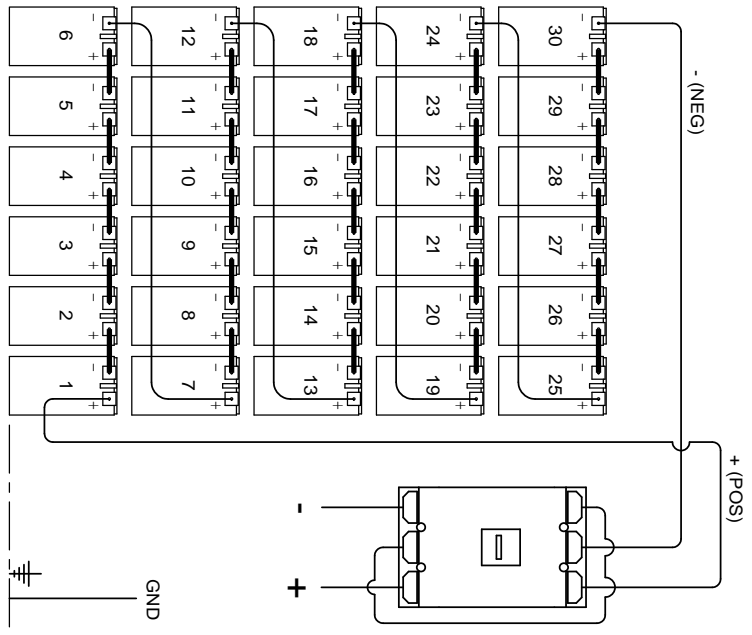
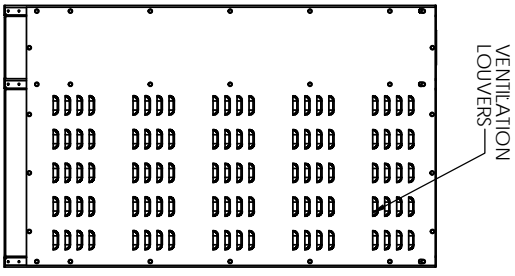
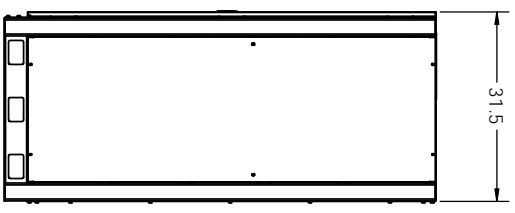
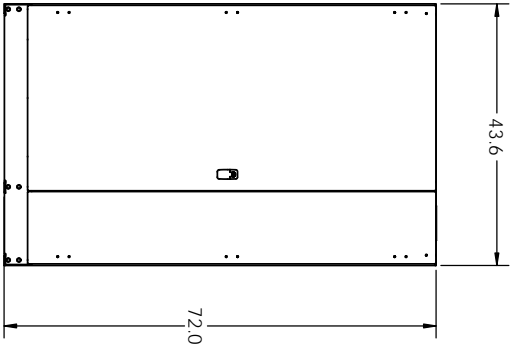
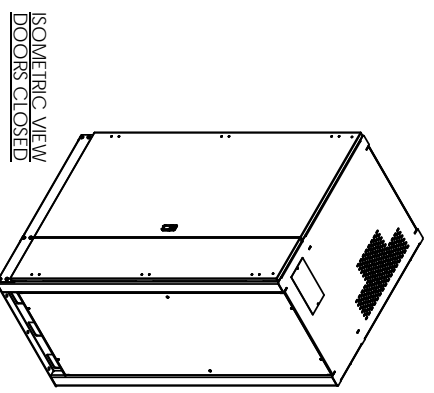
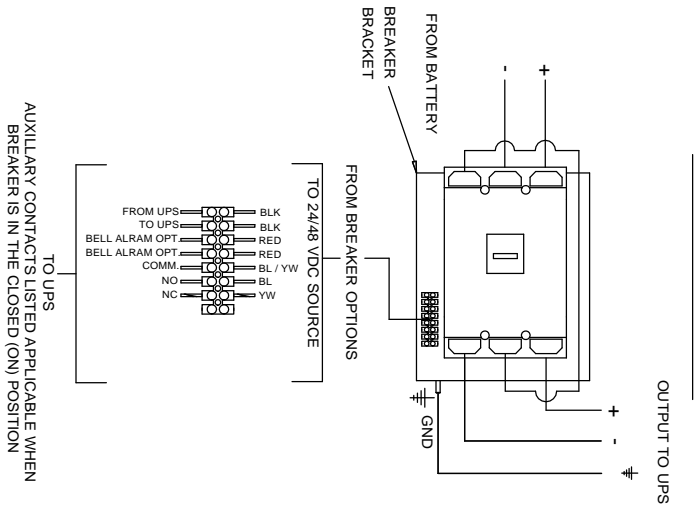

PROHIBITARY AND COMMERCIAL

THE INFORMATION CONTAINED IN THIS DRAWING IS THE PROPERTY OF ESS. IT IS TO BE USED FOR THE PROJECT AND SITE SPECIFICALLY IDENTIFIED HEREIN. ANY REUSE OR MODIFICATION OF THIS DRAWING WITHOUT THE WRITTEN PERMISSION OF ESS IS PROHIBITED.

NAME	DATE	TITLE
RUJ	1/17/17	ESS ELECTRONIC SYSTEMS SUPPORT
RNA	1/17/17	www.ess.io

3233 W. Kingsley Rd.  
Garland, Texas 75041  
PH: 972-722-2468  
FAX: 972-276-9844

DRAWN	DATE	PROJECT
RUJ	1/17/17	ESS ELECTRONIC SYSTEMS SUPPORT
RNA	1/17/17	UNITS CHANGES SPECIFIED
DWG. NO.	DOC. NO.	REV
480V, SIDE BRKR, 30 BLOCs	DOC-014600	A

DO NOT SCALE DRAWING | SHEET 1 OF 1



- NOTES:
1. NEMA 1 DESIGN
  2. EMPTY CABINET WEIGHT: 620 LBS (282 KG)
  3. SEE TABLE FOR LOADED WEIGHTS

BATTERY CABINET LOADED WEIGHTS		
MFG	BATTERY MODEL	WEIGHT(LBS)
EMDEVC	16HX925F-FR	4344

**BREAKER DETAIL**

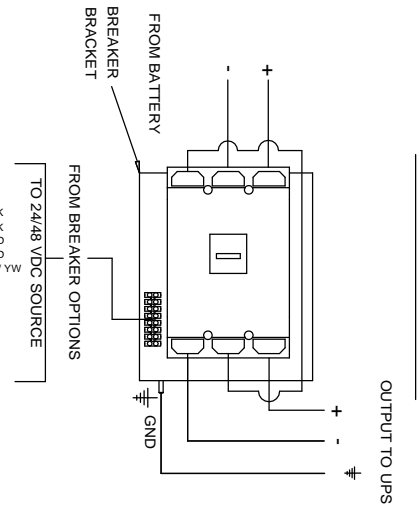

AUXILIARY CONTACTS LISTED APPLICABLE WHEN BREAKER IS IN THE CLOSED (ON) POSITION

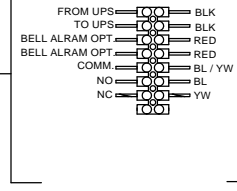

TOP VIEW

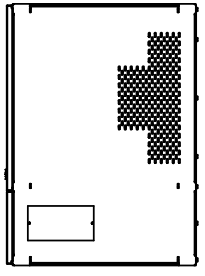

43.6

72.0

FRONT VIEW

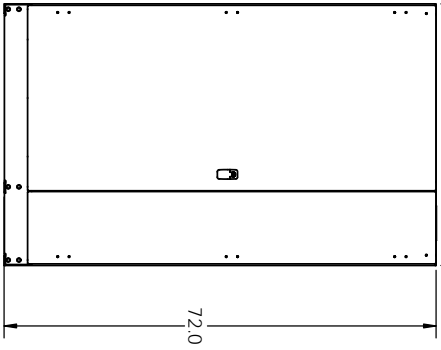

31.5

SIDE VIEW

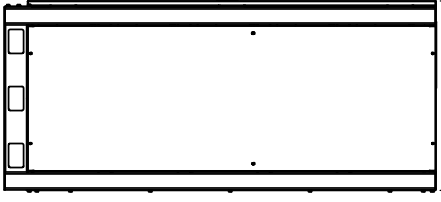

VENTILATION LOUVERS

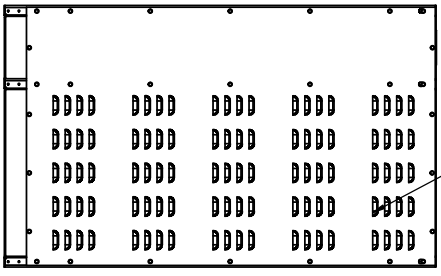

REAR VIEW

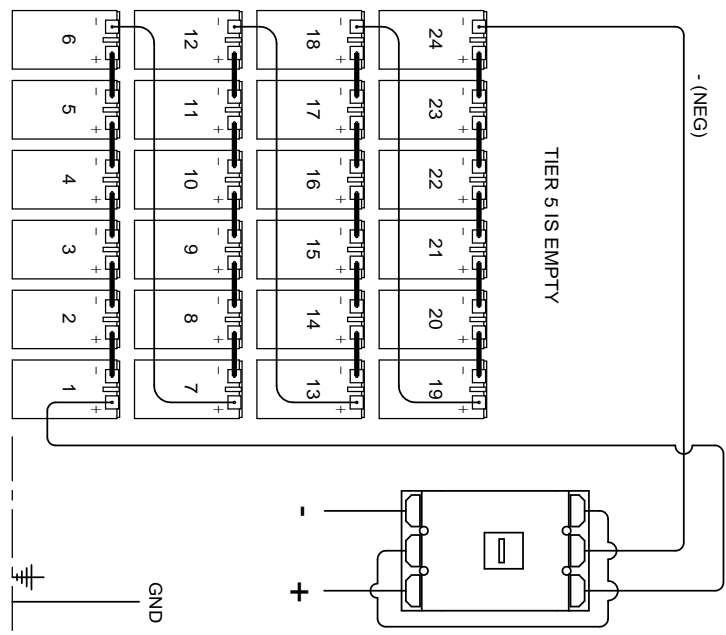
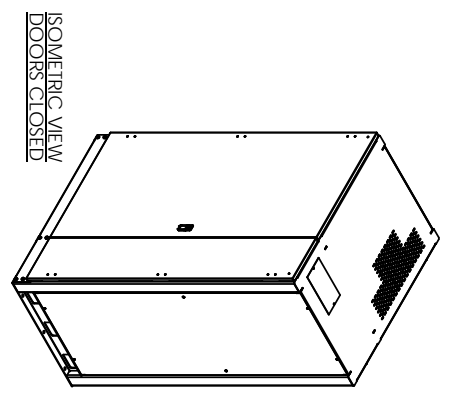

PROHIBITARY AND CONFIDENTIAL

THE INFORMATION CONTAINED IN THIS DOCUMENT IS UNCLASSIFIED EXCEPT WHERE SHOWN OTHERWISE BY THE APPLICABLE E.O. 13526

ESS ELECTRONIC SYSTEMS SUPPORT  
www.ess.io

3233 W. Kingsley Rd.  
Garland, Texas 75041  
PH: 972-272-2468  
FAX: 972-276-9844

NAME:	DATE:	TITLE:
RNAJ	1/17/17	ESCAB BATTERY CABINET,
RNAJ	1/17/17	384V, SIDE BRKR, 24 BLOCs
UNLESS OTHERWISE SPECIFIED,	DWG. NO.	REV
DIMENSIONS ARE IN INCHES	DOC-014700	A

PROJECTION: DO NOT SCALE DRAWING | SHEET 1 OF 1



## NOTES



---

## NOTES



3233 W. Kingsley Rd. • Garland, TX 75041 • Ph: 972-272-2468 • Fax: 972-272-276-9844 • [www.ess.to](http://www.ess.to)