

EFC52/EFC54 SERIES

BATTERY CABINET

INSTALLATION, OPERATION, AND MAINTENANCE MANUAL



This manual provides instructions regarding safety, storage, installation, operation and maintenance. Failure to observe the precautions as presented may result in injury or loss of life.

This document is proprietary to Electronic Systems Support (ESS). This document cannot be copied or reproduced in whole or in part, nor can its contents be revealed in any manner or to any person except to meet the purpose for which it was delivered, without the express written permission of Electronic Systems Support.

Please visit ess.to to check for updates to manual.



TABLE OF CONTENTS

1. INTRODUCTION	2
2. PRECAUTIONS.....	2
3. INSPECTION UPON RECEIPT OF GOODS	3
3.1 General	3
3.2 Visible damage	3
3.3 Concealed damage	3
3.4 Return of damaged goods	3
4. SYSTEM OVERVIEW	3
5. GENERAL SYSTEM SPECIFICATIONS.....	4
5.1 DC Output Characteristics	4
5.2 Batteries.....	4
5.3 Grounding.....	4
5.4 Environmental Conditions.....	4
• Cabinet Dimensions	4
• Cabinet Weights (Assembled)	5
6. INSTALLATION PROCEDURES.....	5
6.1 Preparation	5
6.1.1 Necessary Equipment and Tools	5
6.1.2 Equipment Inspection	5
6.1.3 Safety Precautions	6
7. INSTALLATION STEPS	6
7.1 Cabinet Location.....	6
7.2 Cabinet Mounting	6
7.3 DC Connections	7
7.4 Grounding.....	7
7.5 System Operation	7
8. SYSTEM MAINTENANCE.....	8
8.1 Blown Fuse Replacement.....	8
8.2 Battery Replacement Steps.....	8
9. WARRANTY RELATED MAINTENANCE	
10. DRAWINGS/SCHEMATICS	10
• General Cabinet Drawing.....	10
• Anchor Specifications	11
• Anchor Placement Dimensions.....	12-13
• 480V, EFC52 Top Breaker – Mechanical/Electrical Drawing	14
• 384V, EFC52 Top Breaker – Mechanical/Electrical Drawing	15
• 360V, EFC52 Top Breaker – Mechanical/Electrical Drawing	16
• 384V, EFC42 Top Breaker – Mechanical/Electrical Drawing	17
• 288V, EFC42 Top Breaker – Mechanical/Electrical Drawing	18
• 480V, EFS52 Side Breaker – Mechanical/Electrical Drawing	19
• 384V, EFS52 Side Breaker – Mechanical/Electrical Drawing	20
• 480V, EFC54 Top Breaker – Mechanical/Electrical Drawing	21
• 384V, EFC54 Top Breaker – Mechanical/Electrical Drawing	22
• 360V, EFC54 Top Breaker – Mechanical/Electrical Drawing	23
• 384V, EFC44 Top Breaker – Mechanical/Electrical Drawing	24
• 288V, EFC44 Top Breaker – Mechanical/Electrical Drawing	25
• 480V, EFS54 Side Breaker – Mechanical/Electrical Drawing	26
• 384V, EFS54 Side Breaker – Mechanical/Electrical Drawing	27
• 360V, EFC51 Top Breaker – Mechanical/Electrical Drawing	28
• Notes Page	29











1. INTRODUCTION

ESS EFC52 & EFC54 Series Front Terminal Battery Cabinets are shipped partially assembled, internally pre-wired and come standard with an over current breaker. The removable hinged front doors and removable rear cover also allow for easier battery access. Maintenance rear covers are not needed since all batteries come with nylon straps for easier lifting and moving. Refer to the battery layout drawings and schematics at the end of this manual. Consult the battery manufacturer's battery operation and maintenance manual for complete instructions.

These battery systems are Hi-Pot tested to UL 1778 standards at the factory prior to shipment. All system settings are also adjusted at this time according to the specification sheet. Sales support for future equipment or upgrades is provided by our sales staff and qualified representatives. All technical questions and service issues should be directed to our office 972-272-2468.

2. PRECAUTIONS

-  **It is very important to read, understand and follow the instructions in this manual. Also note all SAFETY PRECAUTIONS before beginning the installation of this system.**
-  **Consult the Battery Manufacturer's Operation and Maintenance Manual for important battery information.**
-  **Battery cabinet systems are very heavy. Total weight of a loaded cabinet can exceed 6100 lbs. Use at least 3 people when unloading and setting equipment in place.**
-  **It is imperative that only qualified personnel work on this system and installation, maintenance or upgrades be performed with insulated tools and equipment.**
-  **When installing this battery system, follow all applicable federal, state and local regulations and industry guidelines to insure a proper installation.**
-  **DC power and battery supplies are dangerous and have extremely high short circuit currents. Severe burns or death can result from a system short. They also can leak potentially explosive gas (hydrogen). Never enclose batteries or battery cabinets in a sealed air tight room.**
-  **All jewelry and watches must be removed prior to installing or servicing this system.**
-  **Do not smoke or present flame near or around any battery cabinet system.**
-  **Never leave a panel off or door open and unattended.**

3. INSPECTION UPON RECEIPT OF GOODS

3.1 General

Special precautions and care have been taken to ensure the cabinet system arrives safe and undamaged. However, upon receipt, you should inspect the entire shipment, including the crate and any boxes for evidence of damage that may have occurred during transit.



3.2 Visible Damage

It is the responsibility of the person receiving the shipment to inventory and fully inspect all materials against the bill of lading or way bill IMMEDIATELY, while the carrier representative is still present. Ensure that all items are accounted for, including number of skids and quantity of boxes. Also note any visible external damage that may have occurred during transit. Make all applicable notations on the delivery receipt before signing and file a damage report with the carrier.

3.3 Concealed Damage

Within 30 days of receipt, unpack the cabinet system and check for any concealed damage. Check the materials received against the detailed packing list to verify the quantity and the condition as complete and satisfactory.

Note any damage to the internal packaging, then request an inspection by the carrier and file a concealed damage claim. If there is a material shortage, contact ESS at the number listed at the end of this manual.

Please contact your shipping company for all shipping damage. ESS is not responsible for any shipping damage.

3.4 Return of Damaged Goods

A RMA number must be obtained before returning equipment to ESS. Please contact an ESS representative or call the corporate number listed at the end of this manual.

4. SYSTEM OVERVIEW

The enclosed cabinet systems provide the necessary DC backup power required in UPS applications. Over-current breaker/fuse protection is supplied. DC connections are front accessible and made via terminal blocks and/or mechanical lugs. Refer to the drawings and schematics at the end of this manual for these connections. Cabinets are equipped with 3-pole breakers. There are 2 holes per polarity on 300 Amp to 600 Amp breakers. Breakers 30 Amps to 250 Amps have a single hole per polarity. **See table below for standard output lug sizes of breakers.**

BREAKER SIZING						
BREAKER SIZE AMPS	30A	40A	50A	75A	100A	125A
A.I.C. RATING, 500DC	20,000 A.I.C	20,000 A.I.C	20,000 A.I.C	20,000 A.I.C	20,000 A.I.C	20,000 A.I.C
OUTPUT LUG SIZE	(1)#14-3/0	(1)#14-3/0	(1)#14-3/0	(1)#14-3/0	(1)#14-3/0	(1)#4-3/0
BREAKER SIZE AMPS	150A	175A	200A	225A	250A	300A
A.I.C. RATING, 500DC	20,000 A.I.C	20,000 A.I.C	20,000 A.I.C	20,000 A.I.C	20,000 A.I.C	20,000 A.I.C
OUTPUT LUG SIZE	(1)#4-4/0	(1)#4-4/0	(1)3/0-350	(1)3/0-350	(1)3/0-350	(2) 2/0-500
BREAKER SIZE AMPS	350A	400A	450A	500A	600	
A.I.C. RATING, 500DC	20,000 A.I.C	20,000 A.I.C	20,000 A.I.C	20,000 A.I.C	20,000 A.I.C	
OUTPUT LUG SIZE	(2) 2/0-500	(2) 2/0-500	(2) 2/0-500	(2) 2/0-500	(2) 2/0-500	

During normal conditions the UPS supplies the load power and the necessary power required to keep the batteries at the proper float voltage. Verify that the charger is set to charge parameters within the approved float voltage range of the batteries, refer to manufacturer's battery operation and maintenance manual.

When AC fails, the batteries discharge in order to provide the necessary backup power. It is the responsibility of the customer to make sure the batteries are not discharged below the battery manufacturer's recommendations. Always recharge batteries per manufacturer's battery operation and maintenance manual. Batteries will be damaged if not recharged right away. See the UPS or DC system manual for more information.



5. GENERAL SYSTEM SPECIFICATIONS

5.1 DC Output Characteristics

- **Voltage:** (UPS Application) 48 to 480 VDC Nominal
- **Breaker:** Standard
- **Fuse Type:** Not standard, consult factory. If a fuse is provided, it is only to be replaced by a factory service technician.

CAUTION! Fire Hazard Warning:
Replace only with same type and rating of fuses supplied with the system.

- **Wire Size and Type:** Per NEC and/or local building and electrical codes.
- **Disconnect:** If a fuse has been provided in lieu of a breaker inside the cabinet, a disconnecting method must be provided per NEC code. This may be a fuse switch or circuit breaker. Size accordingly.

5.2 Batteries

- **Type:** Valve Regulated Lead Acid (VRLA), sealed, non-spillable.
- **Voltage:** 12 Volt DC Nominal, Front Terminal Design.

UL approved battery models:

Energys : 12XE1010F-FR, 12XE1110F-FR, 12XE1150F-FR

East Penn: HR3500ET, HR5500ET, HR7500ET

C&D: UPS12-355MRF, UPS12-615MRF, UPS12-700MRF, UPS12-410FRMX, UPS12-1000MRFX

Northstar: NSB12-450RT, NSB12-650RT, NSB12-730RT, NSB155FT, NSB170FT, NSB190FT,
NSB210FT

Fiamm - 12FLX700F

- **Only cabinets with flame retardant batteries are suitable for computer room use!**

5.3 Grounding

- All grounding should be derived from the main building ground source.
- **Note:** All cabinet systems require grounding.

5.4 Environmental Conditions

Breakers are located at the top of the cabinet for EFC configurations. For EFS configurations, the breakers are located on the side of the cabinet. EFC5x and EFS5x cabinets have a maximum battery configuration of 8 wide by 5 tiers high. EFC4x cabinets have a maximum battery configuration of 8 wide by 4 tiers high.



Cabinet Dimensions:

EFC52, Top Breaker is 45.50" W x 29.5" D* x 84.0" H
EFC42, Top Breaker is 45.50" W x 29.5" D* x 72.0" H
EFS52, Side Breaker is 57.75" W x 29.5" D* x 74.8" H
EFC54, Top Breaker is 45.50" W x 31.5" D* x 84.0" H
EFC44, Top Breaker is 45.50" W x 31.5" D* x 72.0" H
EFS54, Side Breaker is 57.75" W x 31.5" D* x 74.8" H

For mounting hole dimensions, please refer to the cabinet layout drawing at the end of this manual. Also included with each order is a floor template to mark anchor locations per cabinet.

Max Cabinet Weights: (Assembled)

Reference the drawings for each individual voltage available for cabinet weights depending on battery manufacturer and model.

- **Temperature:** Normal operating temperatures are between 68°F -77°F. **Note:** Batteries typically should be at 77°F for optimum battery life and performance.
- **Ventilation/Cooling:** Provided through ventilation slots in the rear panel, bottom panel, front door and top of cabinet, thus providing a chimney effect for natural convection cooling. If local codes require forced air exhaust, unused covers serve as conduit entry or duct work entry points.
- **Clearance:** A minimum of four inches is required in both the front and the rear of the cabinet. This refers to obstruction of ventilation only. Clearance around cabinet sides is suggested by NEC and local codes.

CAUTION! Explosion/Fire Hazard Warning:
Batteries can generate potentially explosive gas (hydrogen).
Never enclose batteries or battery cabinets in a sealed, airtight room.

6. INSTALLATION PRODEDURES

BEFORE PROCEEDING WITH INSTALLATION READ THE FOLLOWING:

6.1 Preparation

6.1.1 Necessary Equipment and Tools

- Rigging tools for moving cabinets. Narrow pallet jack and forklift of 8,500 lbs. minimum capacity when moving fully loaded cabinets.
- Heavily insulated assortment of hand tools.
- Digital Voltmeter

6.1.2 Equipment Inspection

Remove the packaging material from the cabinet and inspect for any concealed shipping damage that may have been overlooked upon receipt of goods. Use the packing list to verify the system has all components and cables for installation.













6.1.3 Safety Precautions

DC VOLTAGE WARNING!

Hazardous DC Voltages are present in the battery cabinet. This hazard will always be present, even when the battery system is off-line. Accidental short circuit of the positive and negative terminals will cause tremendous currents to flow resulting in severe burns, fire and possible death. Use extreme caution!

IMPORTANT SAFETY INSTRUCTIONS. SAVE THESE INSTRUCTIONS!!

-  All disconnecting means should be in the open/off position before servicing.
-  All installation drawings and schematics should be reviewed and clearly understood before hooking up this system.
-  Only qualified DC power technicians or electricians should attempt to work on and install this equipment.
-  All jewelry, rings and watches should be removed when working on this equipment.
-  All tool handles and shafts must be heavily insulated.
-  Do not rest any tools or loose cables on top of batteries.
-  Make sure all connections are properly torqued and secure. Torque values are provided on battery label.
-  Do not smoke or present flames near or around any battery system.
-  Always wear safety glasses and gloves and use insulating mats to stand on when working on this system.
-  Do not allow bare skin to come into contact with battery cabinet, as this could result in an electrical shock.
-  Do not install any cable terminations until it has been verified that such a termination will not create a short circuit.

7. INSTALLATION STEPS

7.1 Cabinet Location

Prior to installation, verify floor loading requirements and all applicable codes pertaining to the related equipment. Environmental conditions should also be reviewed. Proper ventilation and cooling must be adequate for optimum battery life and performance. A clearance of 4" is recommended at the front and rear of the cabinet. This refers to obstruction of ventilation only. Clearance around the cabinet sides should be as suggested by NEC and local codes. Ambient temperature should be between 68°F -77°F.

7.2 Cabinet Mounting

1. Remove any remaining packaging materials (cardboard, plastic).
2. Remove the kick plate from the base of the cabinet. Save this kick plate for re-installation later.
3. Unbolt the cabinet from the pallet. Remove the cabinets from the pallet using a forklift rated for at least 8,500 lbs.
4. The battery cabinet is equipped with narrow pallet jack or forklift access openings in the front and rear of the cabinet. Move the equipment into the desired location and set in place.
Note: When applicable, the cabinet labeled "Left" has the breaker and those cabinets should be paired with any of the "Right" labeled cabinets.



5. In order to meet Zone 4 requirements, refer to the Zone 4 ANCHORING drawings included with this manual. The following steps detail the necessary actions to be taken to meet Zone 4 mounting requirements. Check applicable building codes for length and style of anchors to be used with the flooring substrate. Install anchors per manufacturer's instructions.
6. On the floor, mark the location of the 6 mounting holes found at the bottom of the cabinet legs.
7. Use the floor template or hole location drawing provided with each shipment to mark holes for anchors. Use ½" or 13mm anchors. Install anchors per manufacturer's instructions.
8. Move the cabinet into place, align holes, check levelness, and tighten hardware. **Note:** Should any drilling be performed on this equipment, make sure all exposed batteries and connections are completely covered using insulated type mats. Prevent dust from entering cabinets and clear any debris that has collected.
9. Re-install the front kick plate on the cabinet.
10. Install the front doors on the cabinet.
11. If multiple battery cabinets are installed, repeat above steps. Check height and levelness with adjoining cabinets.

7.3 DC Connections

CAUTION!
PLEASE READ ALL SAFETY INSTRUCTIONS BEFORE PROCEEDING.

1. Open the cabinet door and check for any noticeable problems or damage that may have occurred during shipment. Remove the cardboard box from the cabinet (right cabinet in a dual cabinet system). Use the packing list to verify all bus bars, cables, battery covers and hardware required for assembly is available.
2. Review the installation drawing and schematic diagram included in this manual. Cables and bus bars have been left off in the battery string for safety and will need to be installed later.
3. Connect main cables to the circuit breaker, when applicable, inside the cabinet from the UPS or charger source. All cables should be sized per NEC and any other local codes pertaining to this equipment. Refer to the UPS or charger manual for wiring external batteries. **Note:** Make sure charging source is disconnected before making these connections; also verify the battery cabinet is turned off.
4. Connect the battery interconnect bus bars that were left off during shipment and install as shown on the installation drawing included in this manual. Torque connections properly. Torque values are provided on battery label.
5. Install plastic covers onto batteries. Some covers may need to be notched for locations with bus bars and/or cables in upward orientation.

7.4 Grounding

Ground the battery cabinet to the main building ground. A ground stud inside the cabinet is provided for this.

7.5 System Operation

Refer to the UPS or charger manual for start up and operation of system.



8. SYSTEM MAINTENANCE

CAUTION!
PLEASE READ ALL SAFETY PRECAUTIONS BEFORE PROCEEDING

8.1 Blown Fuse Replacement

If a fuse has blown in the system, contact an authorized factory technician to replace it.

CAUTION! Fire Hazard Warning:
Replace only with same type and rating of fuses supplied with the system.

8.2 Battery Replacement Steps

Servicing of batteries should be performed or supervised by personnel knowledgeable about batteries and the required precautions. When replacing batteries, replace with the same type and number of batteries.

CAUTION!
Do not dispose of batteries in a fire. The batteries may explode.
Do not open or mutilate batteries. Released electrolyte is harmful to the skin and eyes.
It may be toxic.

A battery can present a risk of electrical shock and high short-circuit current. The following precautions should be observed when working on batteries:

- Remove jewelry, rings, watches or other metal objects.
 - Use tools with insulated handles.
 - Wear rubber gloves and boots. Wear safety glasses.
 - Do not lay tools or metal parts on top of batteries.
 - Disconnect charging source prior to connecting or disconnecting battery terminals.
 - Determine if the battery is inadvertently grounded. Remove string from buss and check voltages to ground. Contact with any part of a grounded battery can result in electrical shock. The likelihood of such shock can be reduced if such grounds are removed during installation and maintenance (applicable to equipment and remote battery supplies not having a grounded supply circuit).
1. Prepare the new battery for installation. Check to make sure the battery is the same type and amp-hour rating. Use a non-metallic brush or scotch brite pad to clean the terminals. Apply a light coat of No-ox grease to the terminal to avoid corrosion "per battery manufacturer's recommendation".
 2. Disconnect the charger or UPS from the battery string by opening the breaker.
 3. Remove the center jumper on the battery string to reduce the voltage. If replacing all batteries, continue reducing the voltage in this manner.
 4. Disconnect the interconnect bus bars and/or cables from the battery to be replaced.
 5. Remove the old battery.
 6. Install the new battery. Make sure the new battery is installed the same way regarding polarity orientation and verify with drawing.



7. Reconnect bus bars and/or cables to the battery. Make sure connections are properly torqued. Torque values are provided on the battery label.
8. Reconnect the center jumper. Make sure connections are properly torqued. Torque values are provided on the battery label.
9. Check voltage at terminal block.
10. Close breaker when ready. If your model has a disconnect with an exterior handle to the door, close and latch the door first before closing the breaker.

9. WARRANTY RELATED MAINTENANCE

1. The purchaser (user) shall give freshening charges to the battery a minimum of every six (6) months for Lead-Calcium batteries after shipment from the factory and until final installation. Refer to the installation and maintenance instructions for maximum storage intervals at different environmental situations. Extreme heat could cause more frequent freshening charges.
2. At least once every twelve (12) months, purchaser (user) must take readings and record information per battery manufacturer's installation/maintenance instructions. These records must be maintained for warranty claim purposes. If warranty records are not kept, the warranty shall be null and void.
3. Parallel strings should be limited to five (5) strings
4. Movement of batteries from original point of installation shall immediately void the product warranty, except with the expressed written consent from ESS.
5. Any storage shall be in a dry area having ambient temperature of 77° F (25° C), or less, and in accordance with battery manufacturer published installation, operation and maintenance instructions. Failure to follow the battery manufacturer's published guidelines and/or instructions may invalidate the product warranty, at the sole discretion of ESS.
6. During service or extended storage, a battery system monitor is recommended to be used to record temperatures, voltages, AC ripple, Float currents, Discharge and more to provide more accurate battery and environmental data for warranty with battery manufacturer's claims.



10. DRAWINGS/SCHEMATICS

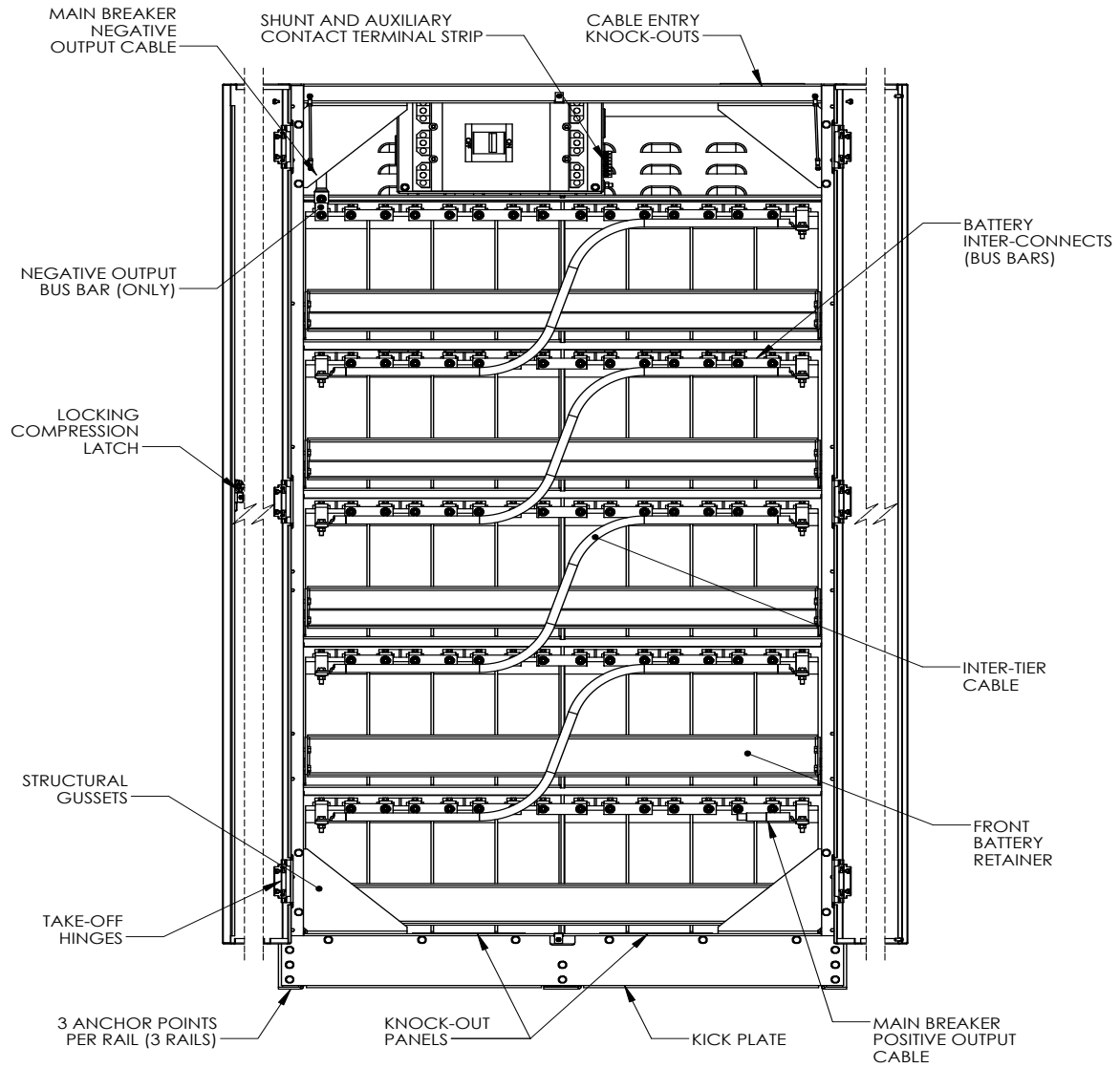

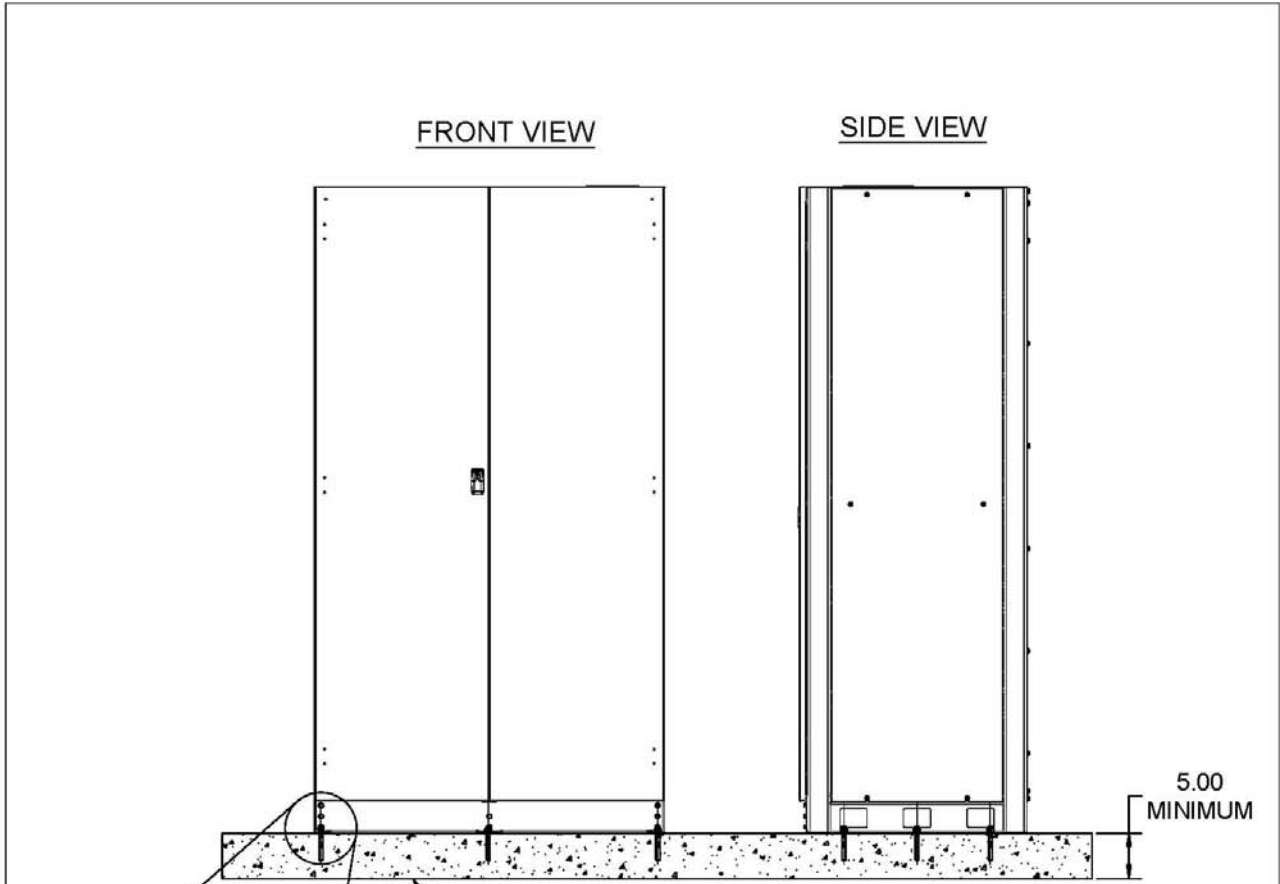

FRONT VIEW

SIDE VIEW

5.00
MINIMUM

CONCRETE FLOOR
MIN. 2000 PSI

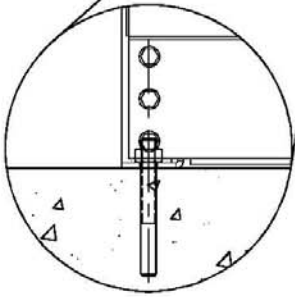

1/2" DIA. HILTI KB-II EXPANSION ANCHORS
PER ER-4627

THE BATTERY CABINETS HAVE BEEN CERTIFIED TO THE IBC 2012, SECTION 1621 & 1622. CABINET MUST BE ANCHORED WITH 6 HILTI KB-II EXPANSION BOLTS OR EQUIVALENT. CHECK APPLICABLE BUILDING CODES FOR LENGTH AND STYLE OF ANCHORS TO BE USED WITH FLOORING SUBSTRATE. INSTALL ANCHORS PER MANUFACTURER'S INSTRUCTIONS. THIS DRAWING IS A STANDARD REPRESENTATION. CABINET CONFIGURATIONS WILL VARY.

PROPRIETARY AND CONFIDENTIAL THE INFORMATION CONTAINED IN THIS DRAWING IS THE SOLE PROPERTY OF ELECTRONIC SYSTEMS SUPPORT. ANY REPRODUCTION IN PART OR AS A WHOLE WITHOUT THE WRITTEN PERMISSION OF ELECTRONIC SYSTEMS SUPPORT IS PROHIBITED.		UNLESS OTHERWISE SPECIFIED: DIMENSIONS ARE IN INCHES	ELECTRONIC SYSTEM SUPPORT www.ess.to	3233 W. Kingsley Rd. Garland, TX 75041 PH. 972-272-2468 FAX 972-276-9844																	
		PROJECTION:		<table border="1"> <tr> <th>NAME</th> <th>DATE</th> <th>TITLE:</th> </tr> <tr> <td>RNA</td> <td>8-21-14</td> <td>EFC52 AND EFC54 SERIES SEISMIC ANCHORING</td> </tr> </table>	NAME	DATE	TITLE:	RNA	8-21-14	EFC52 AND EFC54 SERIES SEISMIC ANCHORING	SIZE	DWG. NO.	REV								
	NAME	DATE	TITLE:																		
	RNA	8-21-14	EFC52 AND EFC54 SERIES SEISMIC ANCHORING																		
USED ON		DO NOT SCALE DRAWING	<table border="1"> <tr> <td>A</td> <td>DOC-004900</td> <td>B</td> </tr> </table>	A	DOC-004900	B	SCALE: NONE	WEIGHT: N/A	SHEET 1 OF 3												
A	DOC-004900	B																			
			<table border="1"> <tr> <td>DRAWN</td> <td>NAME</td> <td>DATE</td> </tr> <tr> <td>CHECKED</td> <td></td> <td></td> </tr> <tr> <td>ENG APPR.</td> <td></td> <td></td> </tr> <tr> <td>MFG APPR.</td> <td></td> <td></td> </tr> <tr> <td>Q.A.</td> <td></td> <td></td> </tr> </table>	DRAWN	NAME	DATE	CHECKED			ENG APPR.			MFG APPR.			Q.A.					
DRAWN	NAME	DATE																			
CHECKED																					
ENG APPR.																					
MFG APPR.																					
Q.A.																					

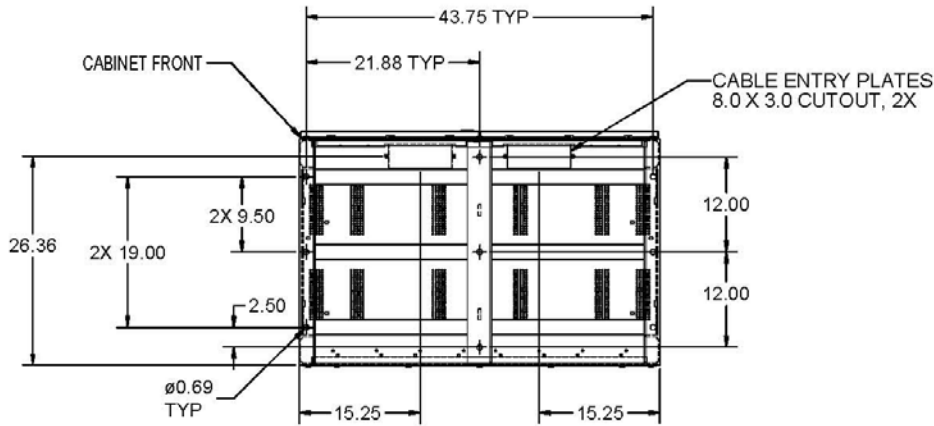

EFC52 FOOT PRINT

40 BLOCS, 480V
32 BLOCS, 384V
30 BLOCS, 360V

EFC42 FOOT PRINT

32 BLOCS, 384V
24 BLOCS, 288V

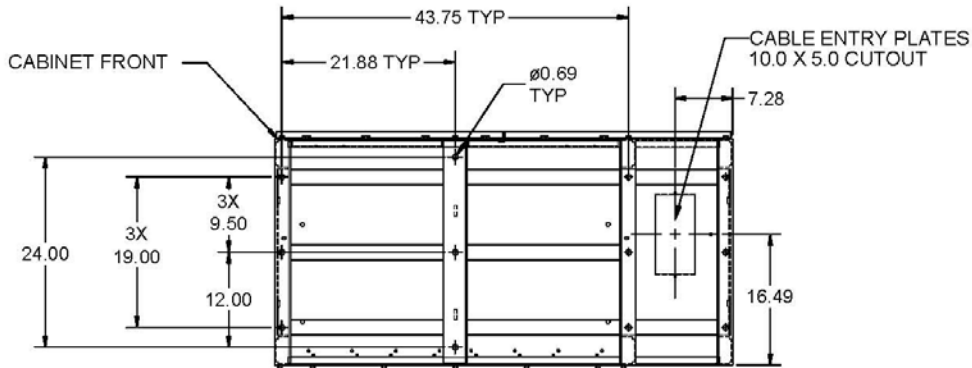

EFS52 FOOT PRINT

40 BLOCS, 480V
32 BLOCS, 384V

PROPRIETARY AND CONFIDENTIAL THE INFORMATION CONTAINED IN THIS DRAWING IS THE SOLE PROPERTY OF ELECTRONIC SYSTEMS SUPPORT. ANY REPRODUCTION IN PART OR AS A WHOLE WITHOUT THE WRITTEN PERMISSION OF ELECTRONIC SYSTEMS SUPPORT IS PROHIBITED.	UNLESS OTHERWISE SPECIFIED, DIMENSIONS ARE IN INCHES		ELECTRONIC SYSTEM SUPPORT www.ess.to		3233 W. Kingsley Rd. Garland, TX 75041 PH. 972-272-2468 FAX 972-276-9844														
	PROJECTION:		<table border="1" style="font-size: small;"> <tr> <th>NAME</th> <th>DATE</th> </tr> <tr> <td>RNA</td> <td>8-21-14</td> </tr> </table>	NAME	DATE	RNA	8-21-14	TITLE: EFC52 AND EFC54 SERIES SEISMIC ANCHORING											
	NAME		DATE																
	RNA		8-21-14																
USED ON	DO NOT SCALE DRAWING	<table border="1" style="font-size: x-small;"> <tr> <td>DRAWN</td> <td>ENG APPR.</td> <td>MFG APPR.</td> <td>Q.A.</td> </tr> <tr> <td>RNA</td> <td></td> <td></td> <td></td> </tr> </table>	DRAWN	ENG APPR.	MFG APPR.	Q.A.	RNA				<table border="1" style="font-size: x-small;"> <tr> <td>SIZE</td> <td>DWG. NO.</td> <td>REV</td> </tr> <tr> <td>A</td> <td>DOC-004900</td> <td>B</td> </tr> </table>	SIZE	DWG. NO.	REV	A	DOC-004900	B	SCALE: NONE WEIGHT: N/A SHEET 2 OF 3	
DRAWN	ENG APPR.	MFG APPR.	Q.A.																
RNA																			
SIZE	DWG. NO.	REV																	
A	DOC-004900	B																	
TITLE:																			

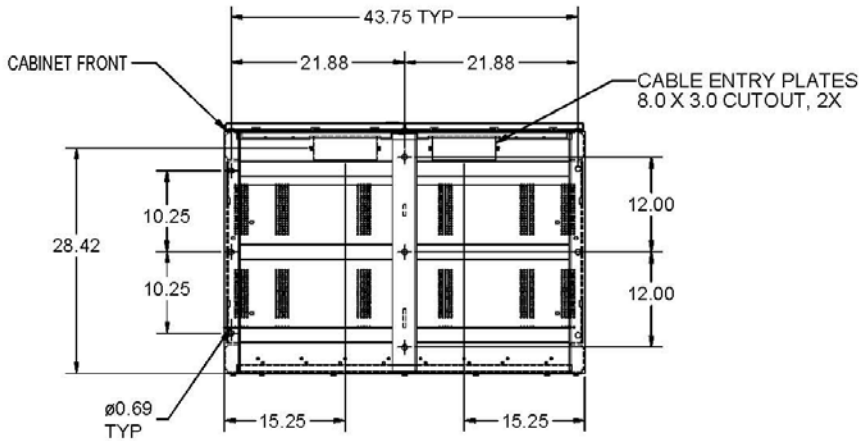

EFC54 FOOT PRINT

40 BLOCS, 480V
32 BLOCS, 384V
30 BLOCS, 360V

EFC44 FOOT PRINT

32 BLOCS, 384V
24 BLOCS, 288V

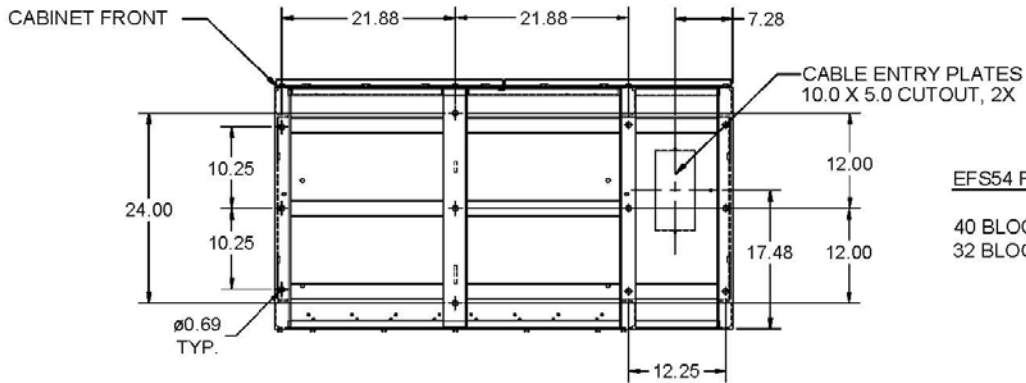

EFS54 FOOT PRINT

40 BLOCS, 480V
32 BLOCS, 384V

PROPRIETARY AND CONFIDENTIAL THE INFORMATION CONTAINED IN THIS DRAWING IS THE SOLE PROPERTY OF ELECTRONIC SYSTEMS SUPPORT. ANY REPRODUCTION IN PART OR AS A WHOLE WITHOUT THE WRITTEN PERMISSION OF ELECTRONIC SYSTEMS SUPPORT IS PROHIBITED.	UNLESS OTHERWISE SPECIFIED:		ELECTRONIC SYSTEM SUPPORT www.ess.to	3233 W. Kingsley Rd. Garland, TX 75041 PH. 972-272-2468 FAX 972-276-9844																								
	DIMENSIONS ARE IN INCHES																											
	PROJECTION:																											
	USED ON	DO NOT SCALE DRAWING																										
			<table border="1"> <tr> <th>NAME</th> <th>DATE</th> <th>TITLE:</th> </tr> <tr> <td>DRAWN RNA</td> <td>8-21-14</td> <td>EFC52 AND EFC54 SERIES SEISMIC ANCHORING</td> </tr> <tr> <td>CHECKED</td> <td></td> <td></td> </tr> <tr> <td>ENG APPR.</td> <td></td> <td></td> </tr> <tr> <td>MFG APPR.</td> <td></td> <td></td> </tr> <tr> <td>Q.A.</td> <td></td> <td></td> </tr> </table>	NAME	DATE	TITLE:	DRAWN RNA	8-21-14	EFC52 AND EFC54 SERIES SEISMIC ANCHORING	CHECKED			ENG APPR.			MFG APPR.			Q.A.			<table border="1"> <tr> <td>SIZE</td> <td>DWG. NO.</td> <td>REV</td> </tr> <tr> <td>A</td> <td>DOC-004900</td> <td>B</td> </tr> </table>	SIZE	DWG. NO.	REV	A	DOC-004900	B
NAME	DATE	TITLE:																										
DRAWN RNA	8-21-14	EFC52 AND EFC54 SERIES SEISMIC ANCHORING																										
CHECKED																												
ENG APPR.																												
MFG APPR.																												
Q.A.																												
SIZE	DWG. NO.	REV																										
A	DOC-004900	B																										
			SCALE: NONE	WEIGHT: N/A	SHEET 3 OF 3																							



- CABINET NOTES:
1. NEMA 1 DESIGN.
 2. EMPTY CABINET WEIGHT: 770 LBS. (350 KG)
 3. SEE TABLE FOR LOADED WEIGHTS.

BATTERY CABINET LOADED WEIGHTS	WEIGHT (LBS)
BATTERY MODEL	
ENERSYS - 12XE1010F-FR	5166
ENERSYS - 12XE1110F-FR	5430
ENERSYS - 12XE1150F-FR	6038
EAST PENN - HR3500ET	4070
EAST PENN - HR3500ET	5670
C&D - UPS12-615VNF	4070
C&D - UPS12-355VNF	5470
C&D - UPS12-700VNF	6110
C&D - UPS12-410VNF	4142
C&D - UPS12-1000VNF	8390
NORTHSTAR - NSB12-450RT	4350
NORTHSTAR - NSB12-650RT	5590
NORTHSTAR - NSB12-730RT	6350
NORTHSTAR - NSB155FT	5710
NORTHSTAR - NSB170FT	6150
NORTHSTAR - NSB190FT	6350
NORTHSTAR - NSB210FT	6950
GNB - S12V645FT	5790
GNB - S12V735FT	6430

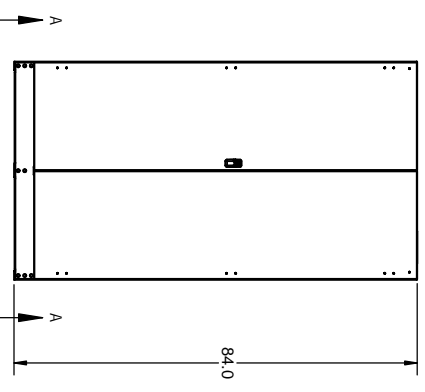
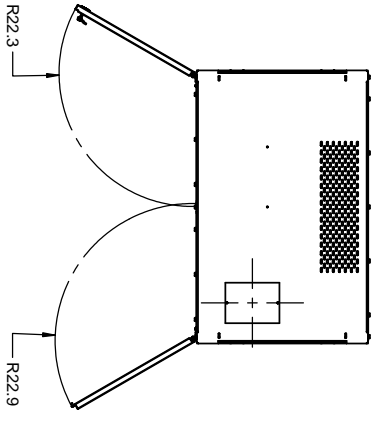

FRONT VIEW

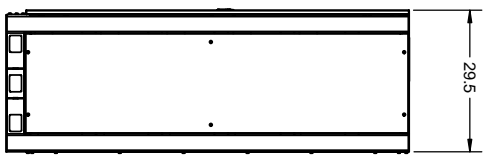

SIDE VIEW

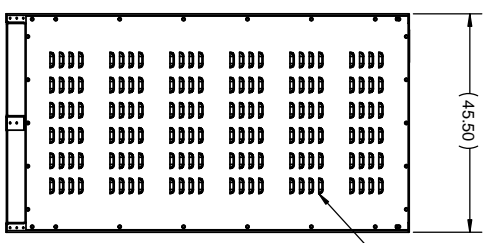

REAR VIEW

BREAKER DETAIL

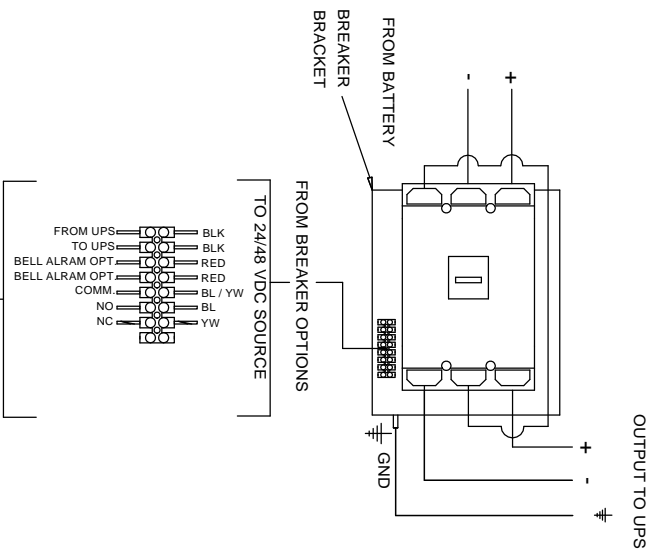

AUXILIARY CONTACTS LISTED APPLICABLE WHEN BREAKER IS IN THE CLOSED (ON) POSITION

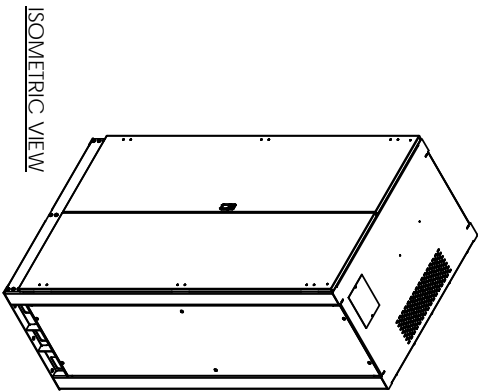

ISOMETRIC VIEW

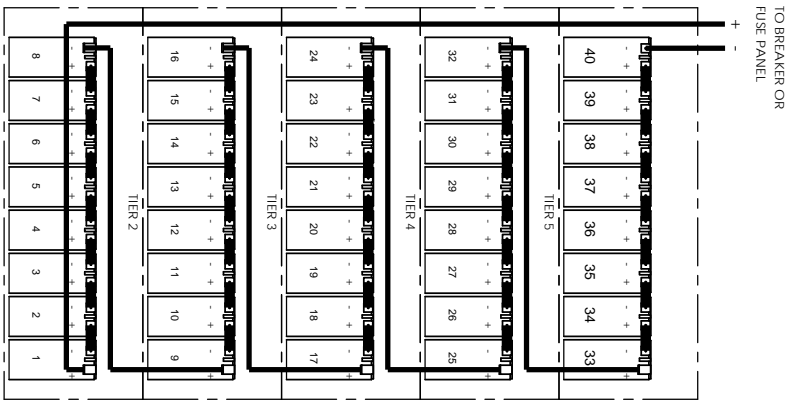

TYP 480V WIRING

PROHIBITARY AND CONFIDENTIAL
 THE INFORMATION CONTAINED IN THIS DRAWING IS THE PROPERTY OF ESS ELECTRONIC SYSTEMS SUPPORT. ANY REPRODUCTION OR TRANSMISSION OF THIS INFORMATION WITHOUT THE WRITTEN PERMISSION OF ESS ELECTRONIC SYSTEMS SUPPORT IS PROHIBITED.

3233 W. Kingsley Rd.
 Garland, Texas 75041
 PH. 972-272-2468
 FAX 972-276-9844

ESS ELECTRONIC SYSTEMS SUPPORT
 www.ess.io

DATE: 8-26-14
 NAME: RNU
 TITLE: EFC52 BATTERY CABINET

DWG. NO. 480V_40 BLOCS
 QUANTITY SPECIFIED: 1
 DIMENSIONS ARE IN INCHES

PROJECTION: DO NOT SCALE DRAWING. SHEET 1 OF 1



CABINET NOTES:

1. NEMA 1 DESIGN
2. EMPTY CABINET WEIGHT: 770 LBS. (350 KG)
3. SEE TABLE FOR LOADED WEIGHTS

BATTERY CABINET LOADED WEIGHTS	WEIGHT (LBS)
BATTERY MODEL	
ENERSYS - 12XE1010F-FR	4294
ENERSYS - 12XE1110F-FR	4518
ENERSYS - 12XE1150F-FR	4998
EAST PENN - HR3500ET	3430
EAST PENN - HR500ET	4710
C&D - UP S12-355MRF	3430
C&D - UP S12-615MRF	4550
C&D - UP S12-700MRF	5062
C&D - UP S12-410MRF	3462
C&D - UPS12-1000MRF	6886
NORTHSTAR - NSB12-450RT	3464
NORTHSTAR - NSB12-650RT	4646
NORTHSTAR - NSB12-730RT	5254
NORTHSTAR - NSB155FT	4742
NORTHSTAR - NSB170FT	5094
NORTHSTAR - NSB190FT	5254
NORTHSTAR - NSB210FT	5734
GNB - S12V645FT	4806
GNB - S12V735FT	5318

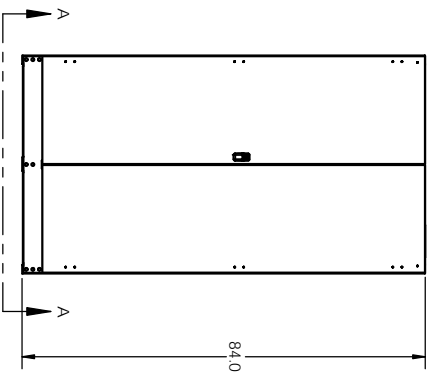
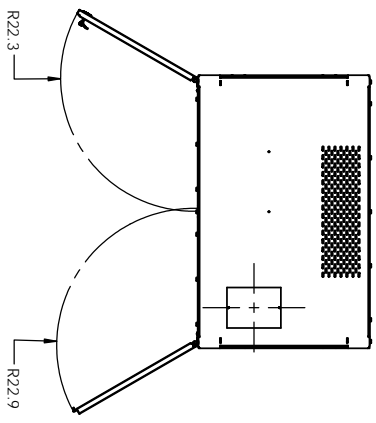

FRONT VIEW

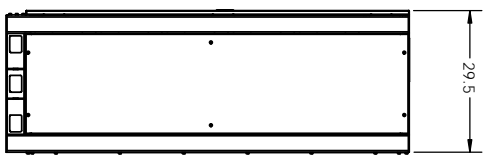

SIDE VIEW

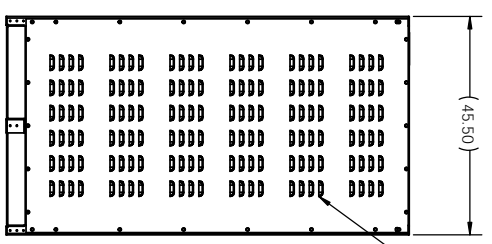

REAR VIEW

BREAKER DETAIL

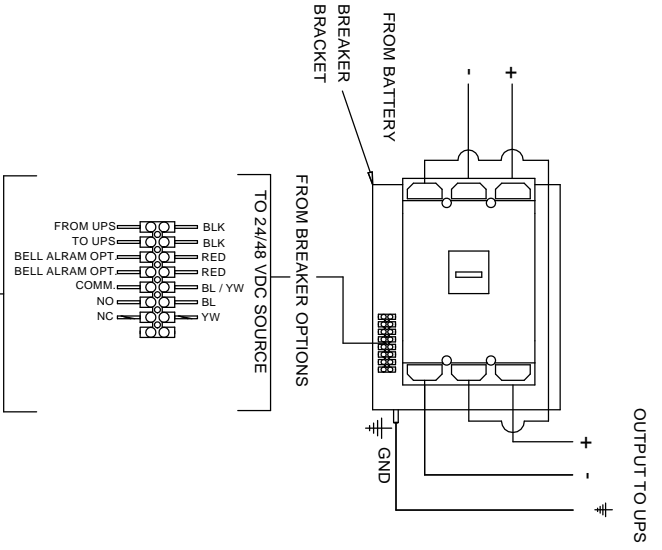

AUXILIARY CONTACTS LISTED APPLICABLE WHEN BREAKER IS IN THE CLOSED (ON) POSITION

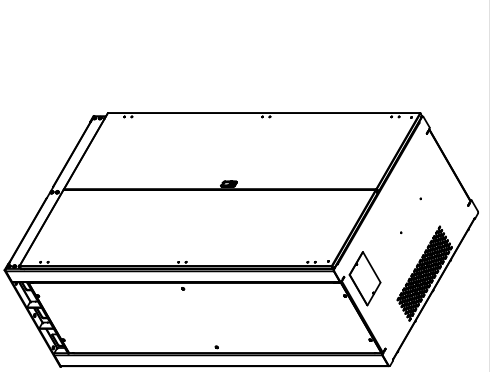

ISOMETRIC VIEW

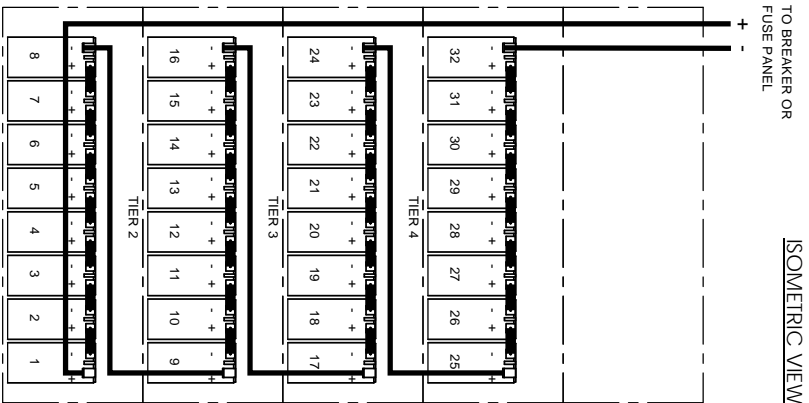

TYP 384V WIRING

PROHIBITARY AND CONFIDENTIAL
 THE INFORMATION CONTAINED IN THIS DRAWING IS UNCLASSIFIED EXCEPT WHERE SHOWN OTHERWISE.
 ELECTRONIC SYSTEMS SUPPORT ANY REPRODUCTION OR TRANSMISSION OF THIS INFORMATION WITHOUT THE WRITTEN PERMISSION OF ELECTRONIC SYSTEMS SUPPORT.

3233 W. Kingsley Rd.
 Garland, Texas 75041
 PH. 972-272-2468
 FAX 972-276-9848
 www.ess.io

ESS ELECTRONIC SYSTEMS SUPPORT

DATE: 8-26-14
 TITLE: EFC52 BATTERY CABINET

DRAWN: RJA
 APPR: RJA

DWG. NO. DOC-005100
 UNLESS OTHERWISE SPECIFIED, DIMENSIONS ARE IN INCHES.

PROJECTION: 1st Angle
 DO NOT SCALE DRAWING. SHEET 1 OF 1

REV B



CABINET NOTES:

1. NEMA 1 DESIGN.
2. EMPTY CABINET WEIGHT: 770 LBS. (350 KG)
3. SEE TABLE FOR LOADED WEIGHTS.

BATTERY CABINET LOADED WEIGHTS	WEIGHT (LBS)
ENERSYS - 12XE1010E-FR	4080
ENERSYS - 12XE1110E-FR	4290
ENERSYS - 12XE1150E-FR	4740
EAST PENN - HR5500ET	3270
EAST PENN - HR5500ET	4470
C&D - UPS12-355MRF	3720
C&D - UPS12-615MRF	4320
C&D - UPS12-700MRF	4800
C&D - UPS12-410MRF	3300
C&D - UPS12-1000MRF	6510
NORTHSTAR - NSB12-450RT	3290
NORTHSTAR - NSB12-650RT	3228
NORTHSTAR - NSB12-730RT	4980
NORTHSTAR - NSB155FT	4500
NORTHSTAR - NSB170FT	4830
NORTHSTAR - NSB190FT	3228
NORTHSTAR - NSB210FT	5430
GNB - S12V645FT	4560
GNB - S12V735FT	5040

BREAKER DETAIL

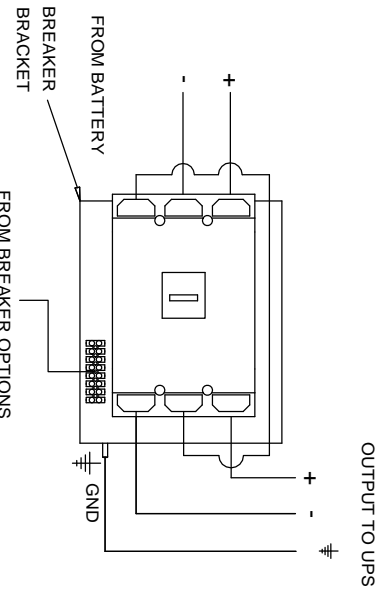

AUXILIARY CONTACTS LISTED APPLICABLE WHEN BREAKER IS IN THE CLOSED (ON) POSITION

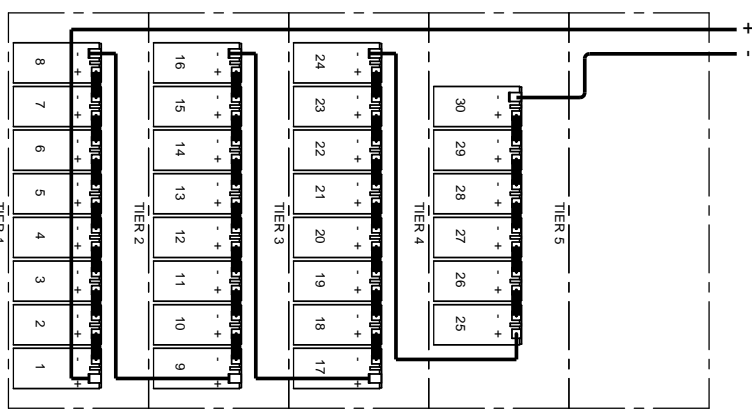
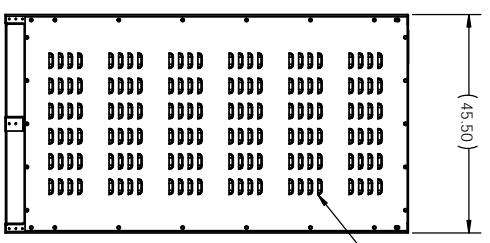
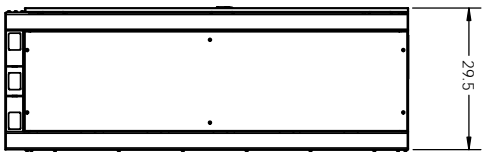
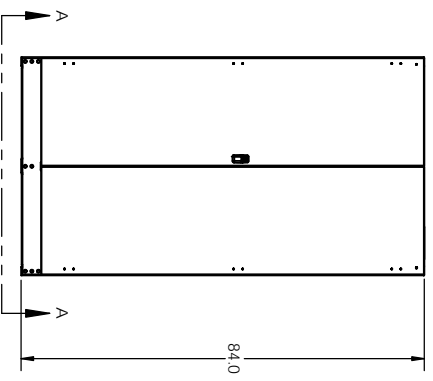
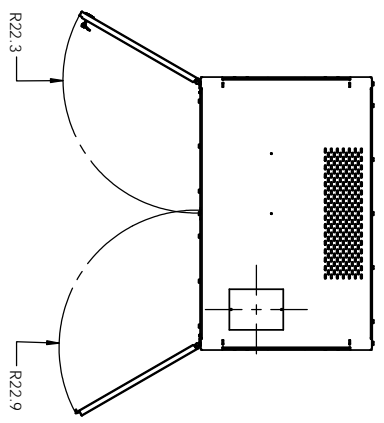
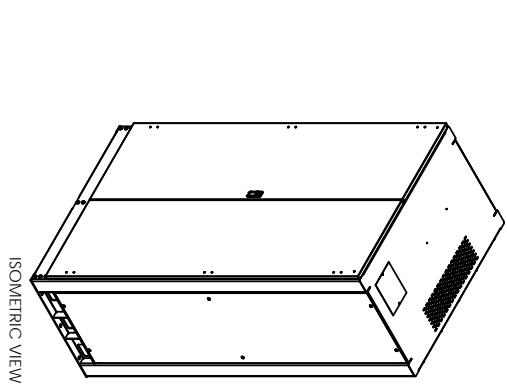
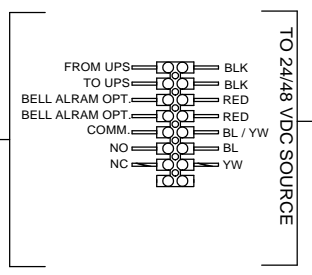

TYP 360V WIRING

PROHIBITARY AND CONFIDENTIAL
 THE INFORMATION CONTAINED IN THIS DRAWING IS THE PROPERTY OF ESS ELECTRONIC SYSTEMS SUPPORT. ANY REPRODUCTION OR TRANSMISSION OF THIS INFORMATION WITHOUT THE WRITTEN PERMISSION OF ESS ELECTRONIC SYSTEMS SUPPORT IS PROHIBITED.

3233 W. Kingsley Rd.
 Garland, Texas 75041
 PH. 972-272-2468
 FAX 972-276-9844
 www.ess.io

ESS ELECTRONIC SYSTEMS SUPPORT
 360V, 30 BLOCS
 BATTERY CABINET

DATE	8/26/14	TITLE	ESS2 BATTERY CABINET
NAME	RNA	DWG. NO.	DOC-005200
APPR.	RNA	REV	B

PROJECTION: DO NOT SCALE DRAWING. SHEET 1 OF 1

FRONT VIEW

SIDE VIEW

REAR VIEW



CABINET NOTES:

1. NEMA 1 DESIGN.
2. EMPTY CABINET WEIGHT: 680 LBS. (309 KG)
3. SEE TABLE FOR LOADED WEIGHTS.

BATTERY MODEL	WEIGHT (LBS)
ENERSYS - 12XE1010F-FR	4204
ENERSYS - 12XE1110F-FR	4428
ENERSYS - 12XE1150F-FR	4908
EAST PENN - HR3500ET	3340
EAST PENN - HR5500ET	4620
C&D - UPS12-355MRF	3340
C&D - UPS12-615MRF	4460
C&D - UPS12-700MRF	4972
C&D - UPS12-410MRF	3397
C&D - UPS12-1000MRF	6796
NORTHSTAR - NSB12-450RT	3564
NORTHSTAR - NSB12-650RT	4556
NORTHSTAR - NSB12-730RT	5164
NORTHSTAR - NSB155FT	4652
NORTHSTAR - NSB170FT	5004
NORTHSTAR - NSB190FT	5164
NORTHSTAR - NSB210FT	5644
GNB - S12V645FT	4716
GNB - S12V735FT	6188

BREAKER DETAIL

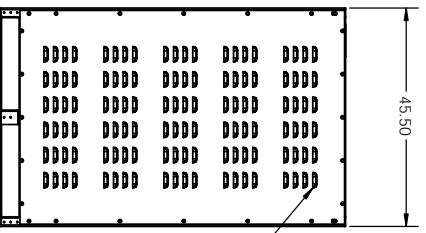
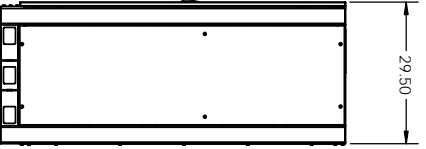
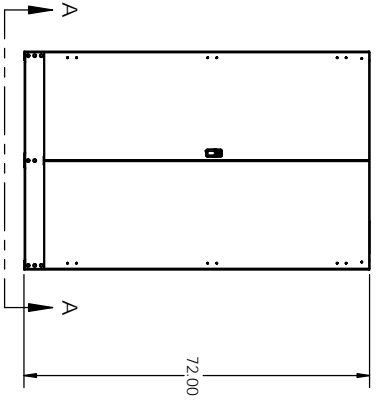
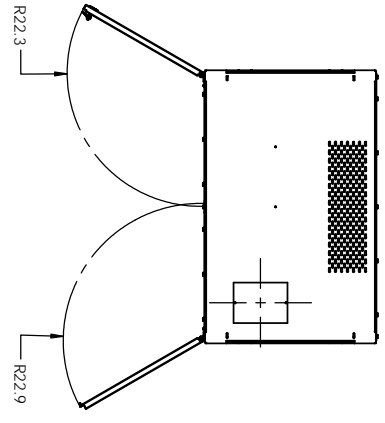
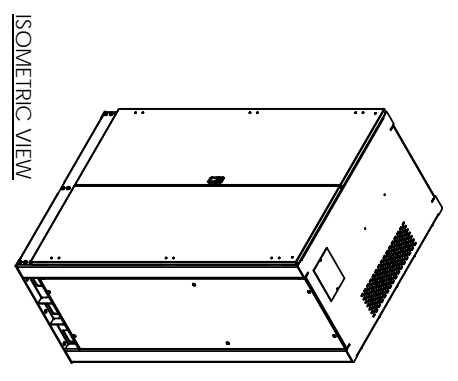
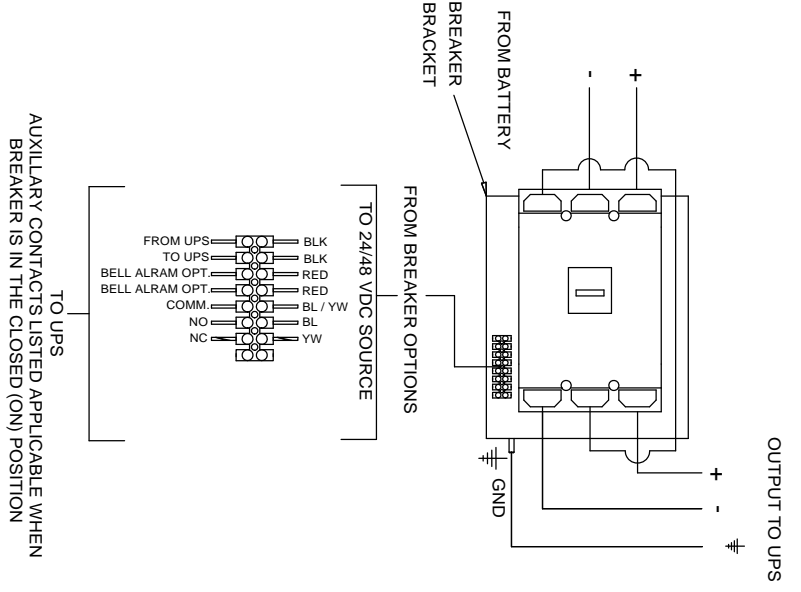

TYP 384V WIRING

PROHIBITARY AND CONFIDENTIAL

THE INFORMATION CONTAINED IN THIS DRAWING IS THE PROPERTY OF ESS ELECTRONIC SYSTEMS SUPPORT. ANY REPRODUCTION OR TRANSMISSION OF THIS INFORMATION WITHOUT THE WRITTEN PERMISSION OF ESS ELECTRONIC SYSTEMS SUPPORT IS PROHIBITED.

DATE	ISSUE	DESCRIPTION
8-26-14	1	ISSUES CHANGES SPECIFIED
8-26-14	2	DIMENSIONS ARE IN INCHES

PROJECTION

DO NOT SCALE DRAWING

SHEET 1 OF 1

ESS ELECTRONIC SYSTEMS SUPPORT
www.ess.io

3233 W. Kingsley Rd.
Garland, Texas 75041
PH. 972.272.2468
FAX 972.276.9844

DWG. NO. DOC-005300

REV B



CABINET NOTES:

1. NEMA 1 DESIGN
2. EMPTY CABINET WEIGHT: 680 LBS (309 KG)
3. SEE TABLE FOR LOADED WEIGHTS.

BATTERY CABINET LOADED WEIGHTS	
BATTERY MODEL	WEIGHT (LBS)
ENERSYS - 12XE1010F-FR	3348
ENERSYS - 12XE1110F-FR	3516
ENERSYS - 12XE1150F-FR	3876
EAST PENN - HR3500ET	2700
EAST PENN - HR5500ET	3660
C&D - UPS12-355WRF	2700
C&D - UPS12-615WRF	3540
C&D - UPS12-700WRF	3924
C&D - UPS12-410WRF	2743
C&D - UPS12-1000WRF	5292
NORTHSTAR - NSB12-450RT	2868
NORTHSTAR - NSB12-650RT	3612
NORTHSTAR - NSB12-730RT	4068
NORTHSTAR - NSB155FT	3684
NORTHSTAR - NSB170FT	3948
NORTHSTAR - NSB190FT	4068
NORTHSTAR - NSB210FT	4428
GNB - S12V645FT	3732
GNB - S12V735FT	4116

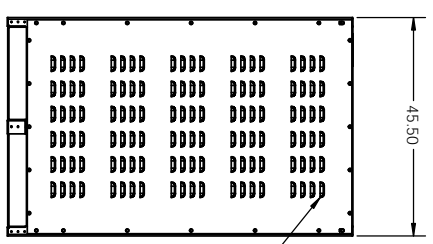
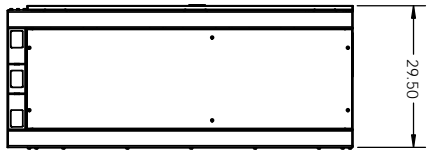
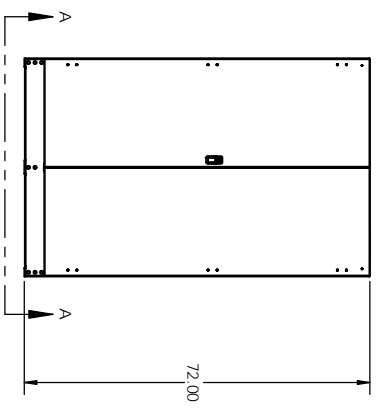
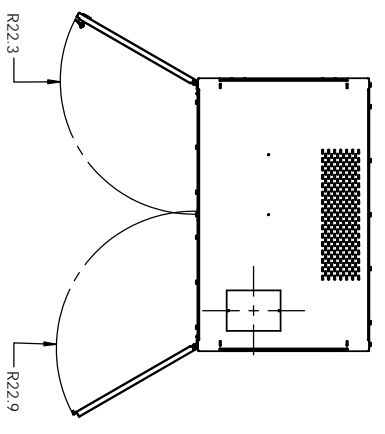

BREAKER DETAIL

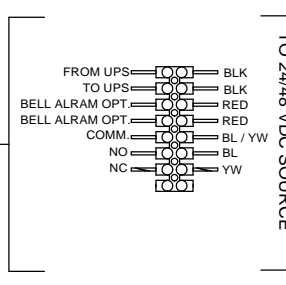
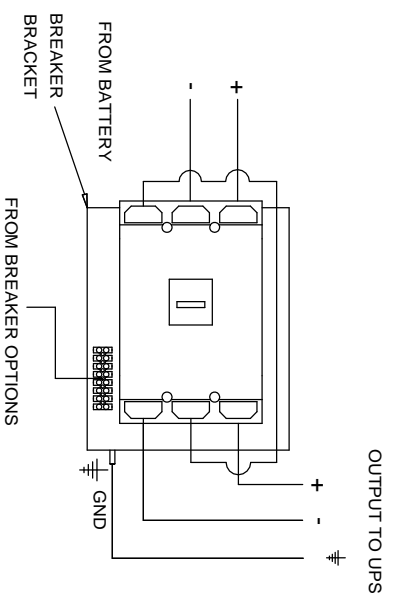

AUXILIARY CONTACTS LISTED APPLICABLE WHEN BREAKER IS IN THE CLOSED (ON) POSITION

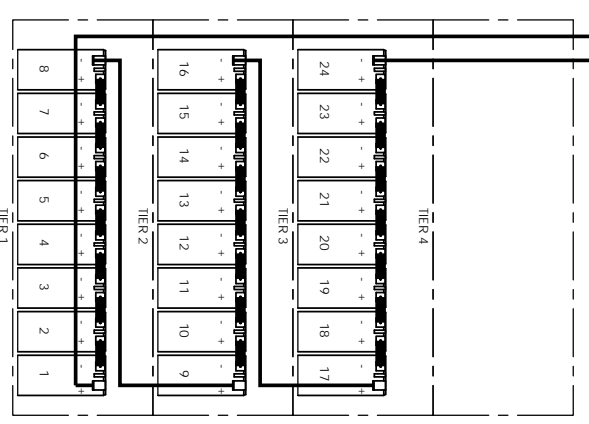
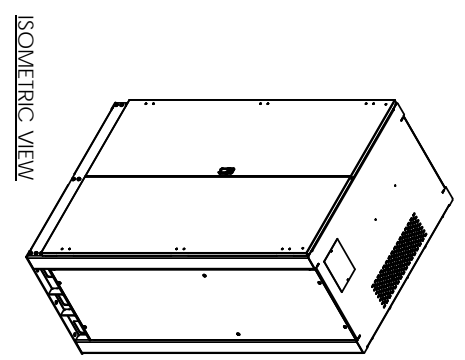

TYP 288V WIRING

PROHIBITARY AND COMMERCIAL
 THE REPRODUCTION OR TRANSMISSION OF THIS DOCUMENT IN ANY FORM OR BY ANY MEANS WITHOUT THE WRITTEN PERMISSION OF ELECTRONIC SYSTEMS SUPPORT IS PROHIBITED.

ESS ELECTRONIC SYSTEMS SUPPORT
 www.ess.io

3233 W. Kingsley Rd.
 Garland, Texas 75041
 PH. 972-272-2468
 FAX 972-278-9844

DATE:	8-26-14	TITLE:	EFFC12 BATTERY CABINET
REV:	8-26-14	DWG. NO.:	288V_24 BLOCs
UNLESS OTHERWISE SPECIFIED		DOC-005500	
DIMENSIONS ARE IN INCHES			
PROJECTION:			REV B
			SHEET 1 OF 1



CABINET NOTES:

1. NEMA 1 DESIGN.
2. EMPTY CABINET WEIGHT: 820 LBS (372 KG)
3. SEE TABLE FOR LOADED WEIGHTS.

BATTERY MODEL	WEIGHT (LBS)
ENERSYS - 12XE1010E-FR	5200
ENERSYS - 12XE1110E-FR	5480
ENERSYS - 12XE1150E-FR	6080
EAST PENN - HR83500ET	4120
EAST PENN - HR83500ET	5720
C&D - UPS12-355MIRF	4120
C&D - UPS12-615MIRF	5520
C&D - UPS12-700MIRF	6160
C&D - UPS12-410MIRF	4192
C&D - UPS12-1000MIRF	8440
NORTHSTAR - NSB12-450RT	4400
NORTHSTAR - NSB12-650RT	5640
NORTHSTAR - NSB12-730RT	6400
NORTHSTAR - NSB155FT	5760
NORTHSTAR - NSB120FT	6200
NORTHSTAR - NSB190FT	6400
NORTHSTAR - NSB210FT	7000
GNB - S12V645FT	5840
GNB - S12V735FT	6480

BREAKER DETAIL

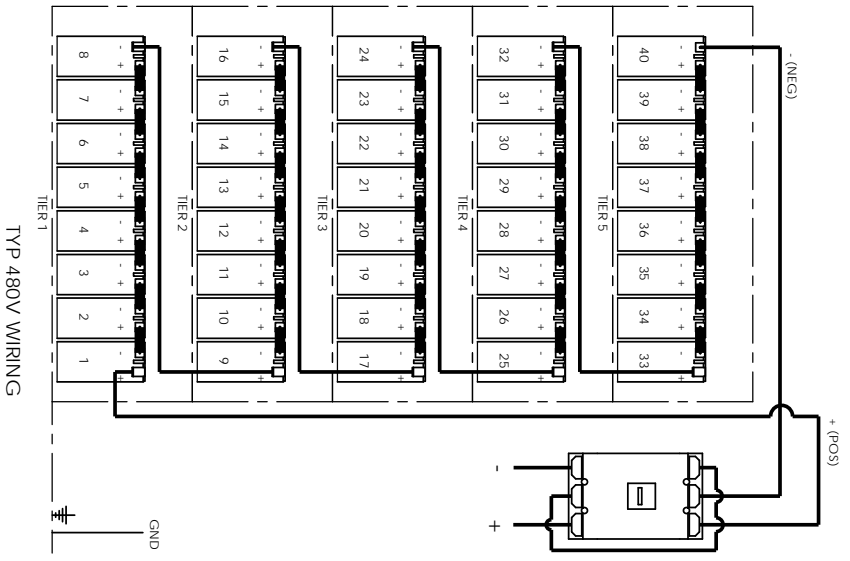
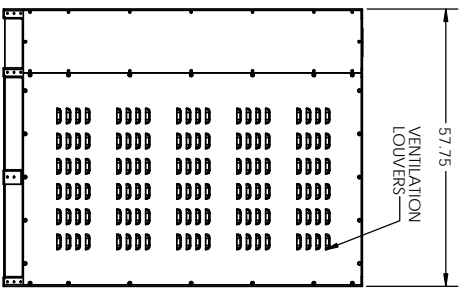
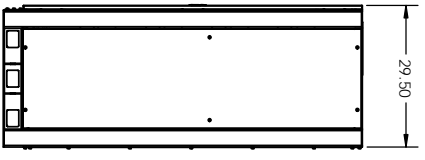
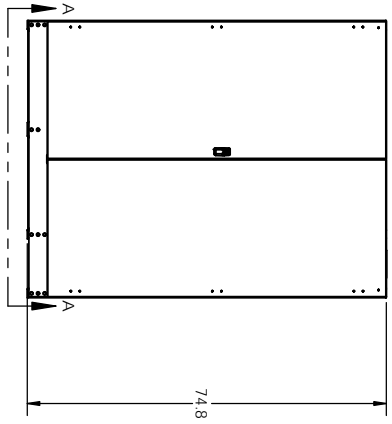
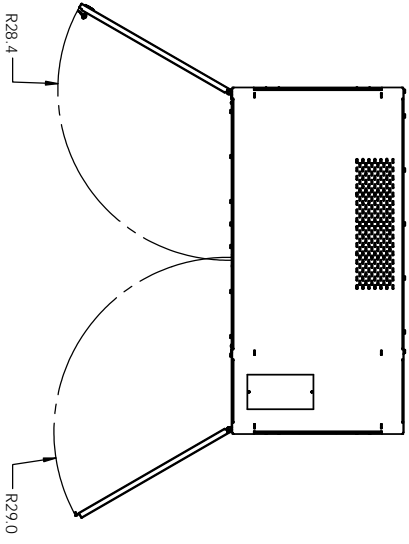
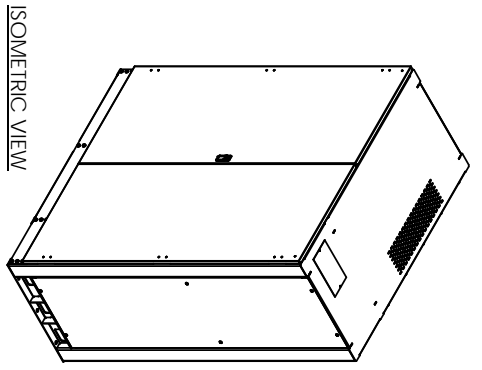
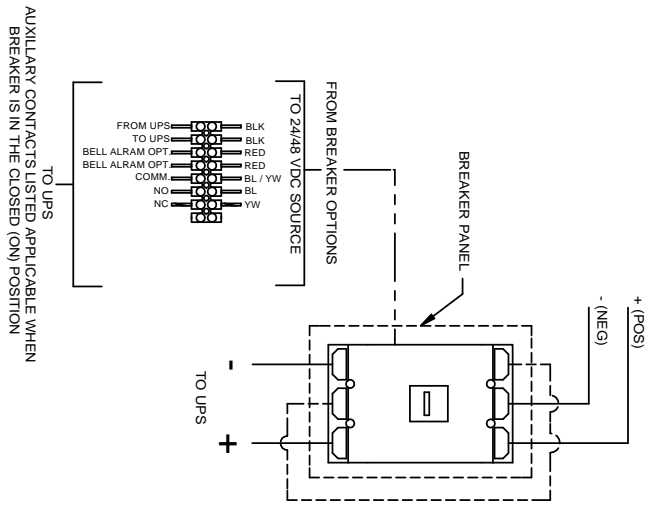

PROHIBITARY AND CONFIDENTIAL

THE INFORMATION CONTAINED IN THIS DRAWING IS THE PROPERTY OF ESS ELECTRONIC SYSTEMS SUPPORT. ANY REPRODUCTION OR TRANSMISSION OF THIS INFORMATION WITHOUT THE WRITTEN PERMISSION OF ESS ELECTRONIC SYSTEMS SUPPORT IS PROHIBITED.

ESS ELECTRONIC SYSTEMS SUPPORT
 www.ess.io

3233 W. Kingsley Rd.
 Garland, Texas 75041
 PH. 972-272-2468
 FAX 972-278-9844

NAME:	DATE:	TITLE:
DRAWN: RNA	8-26-14	ESS2 BATTERY CABINET
APPR: RNA	8-26-14	SIDE BREAKER, 480V, 40 BLOCS
UNLESS OTHERWISE SPECIFIED, DIMENSIONS ARE IN INCHES.	DWG. NO. DOC-005600	REV B
PROJECTION: 1st Angle	DO NOT SCALE DRAWING	SHEET 1 OF 1



CABINET NOTES:

- NEMA 1 DESIGN
- EMPTY CABINET WEIGHT: 820(LBS) (372 KG)
- SEE TABLE FOR LOADED WEIGHTS

BATTERY MODEL	WEIGHT (LBS)
ENERSYS - 12XE1010F-FR	4344
ENERSYS - 12XE1110F-FR	4568
ENERSYS - 12XE1150F-FR	5048
EAST PENN. - HR3500ET	3480
EAST PENN. - HR5500ET	4760
C&D - UPS12-355MRF	3480
C&D - UPS12-615MRF	4632
C&D - UPS12-700MRF	5112
C&D - UPS12-410MRF	3537
C&D - UPS12-1000MRF	6936
NORTHSTAR - NSB12-450RT	3704
NORTHSTAR - NSB12-650RT	4696
NORTHSTAR - NSB12-730RT	5304
NORTHSTAR - NSB155FT	4792
NORTHSTAR - NSB170FT	5144
NORTHSTAR - NSB190FT	5304
NORTHSTAR - NSB210FT	5784
GNB - S12V645FT	4856
GNB - S12V735FT	5368

BREAKER DETAIL

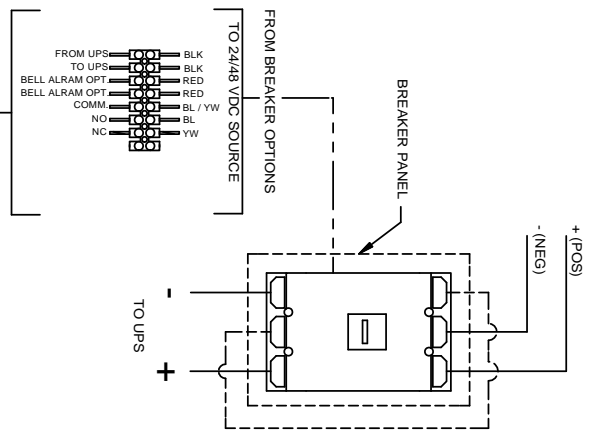

AUXILIARY CONTACTS LISTED APPLICABLE WHEN BREAKER IS IN THE CLOSED (ON) POSITION

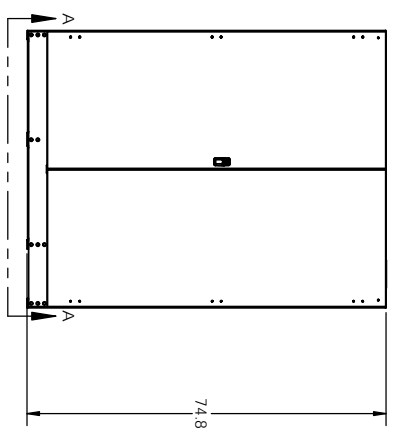
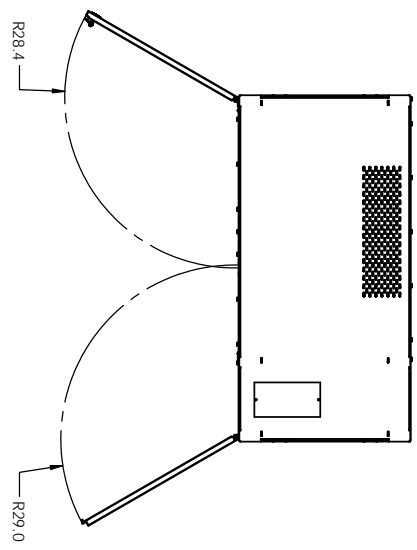

FRONT VIEW

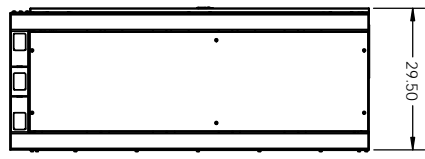

SIDE VIEW

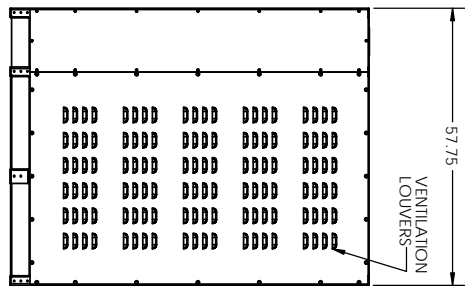

REAR VIEW

ISOMETRIC VIEW

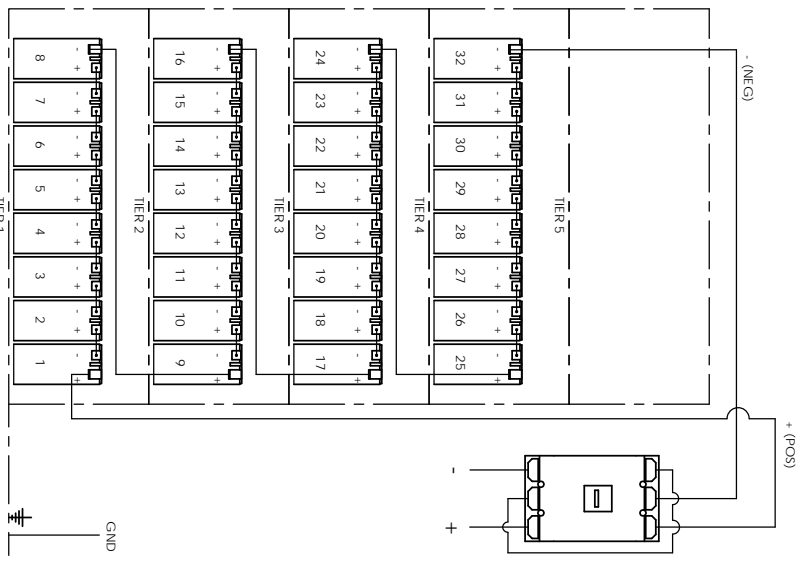
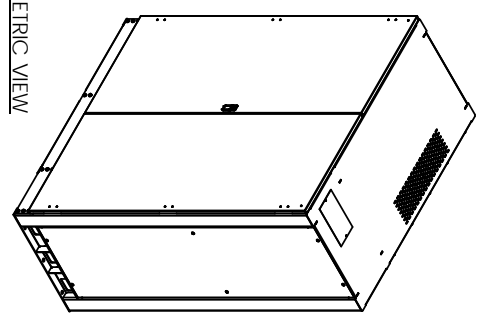

TYP 384V WIRING

PROHIBITARY AND COMMERCIAL

THE INFORMATION CONTAINED IN THIS DOCUMENT IS UNCLASSIFIED EXCEPT WHERE SHOWN OTHERWISE. IT IS THE PROPERTY OF ELECTRONIC SYSTEMS SUPPORT AND IS LOANED TO YOU BY THE INFORMATION SYSTEMS SUPPORT CENTER.

ESS ELECTRONIC SYSTEMS SUPPORT
www.ess.io

3233 W. Kingsley Rd.
Garland, Texas 75041
PH: 972-272-2468
FAX: 972-278-9844

DATE	TITLE
8-26-14	ESS52 BATTERY CABINET
8-26-14	SIDE BREAKER, 384V, 32 BLOCOS
8-26-14	DOC-005700

PROJECTION: DO NOT SCALE DRAWING | SHEET 1 OF 1



- CABINET NOTES:
1. NEMA 1 DESIGN.
 2. EMPTY CABINET WEIGHT: 820 LBS. (370 KG)
 3. SEE TABLE FOR LOADED WEIGHTS.

BATTERY CABINET LOADED WEIGHTS	
BATTERY MODEL	WEIGHT (LBS)
EAST PENN - HR7500ET	6920

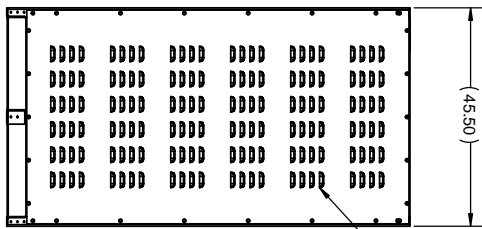
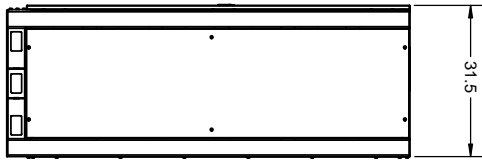
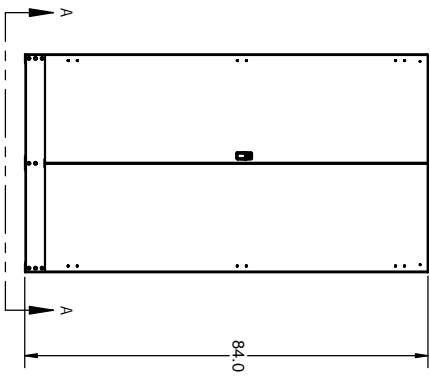
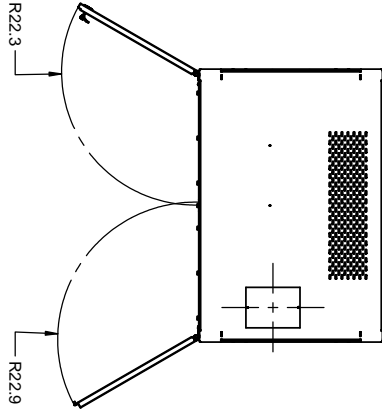

BREAKER DETAIL

OUTPUT TO UPS

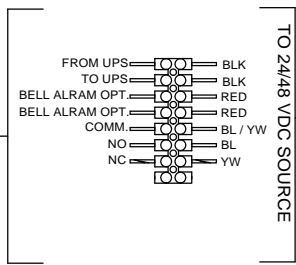
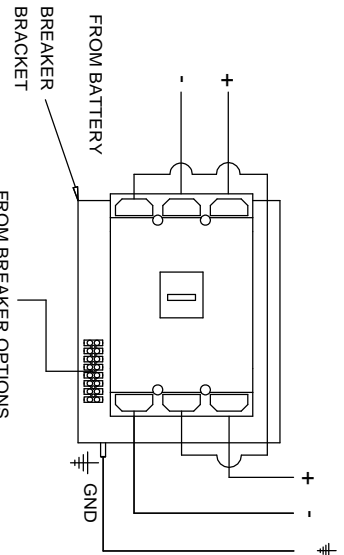

AUXILIARY CONTACTS LISTED APPLICABLE WHEN BREAKER IS IN THE CLOSED (ON) POSITION

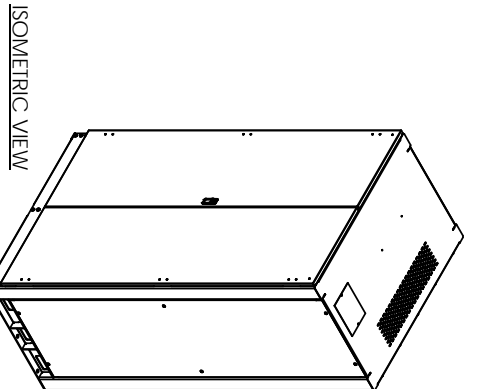

ISOMETRIC VIEW



TYP 480V WIRING

PROHIBITARY AND COMMERCIAL		THE INFORMATION CONTAINED IN THIS DRAWING IS THE PROPERTY OF ESS. IT IS TO BE USED FOR THE PROJECT SPECIFICALLY IDENTIFIED HEREIN. NO OTHER USES OR REPRODUCTION OF THIS DRAWING IS PERMITTED WITHOUT THE WRITTEN PERMISSION OF ESS.	
DATE	TITLE	3233 W. Kingsley Rd. Garland, Texas 75041 PH. 972-272-2468 FAX 972-272-9844	REV
NAME	ESS ELECTRONIC SYSTEMS SUPPORT www.ess.io		A
DATE	12/22/16	DWG. NO.	DOC-012100
BY	RNA	PROJECT	DO NOT SCALE DRAWING
DATE	12/22/16	PROJECT	SHEET 1 OF 1
BY	RNA	PROJECT	
DATE	12/22/16	PROJECT	
BY	RNA	PROJECT	
DATE	12/22/16	PROJECT	
BY	RNA	PROJECT	
DATE	12/22/16	PROJECT	
BY	RNA	PROJECT	



- CABINET NOTES:
1. NEMA 1 DESIGN
 2. EMPTY CABINET WEIGHT: 820 LBS. (370 KG)
 3. SEE TABLE FOR LOADED WEIGHTS

BATTERY CABINET LOADED WEIGHTS	
BATTERY MODEL	WEIGHT (LBS)
EAST PENN - HR7500ET	5720

BREAKER DETAIL

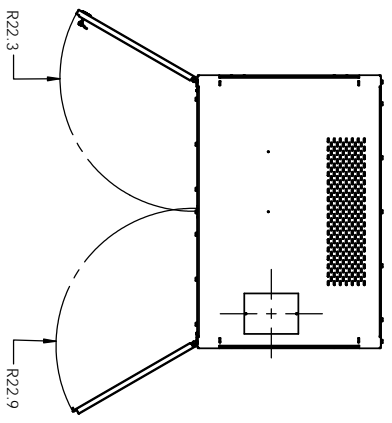
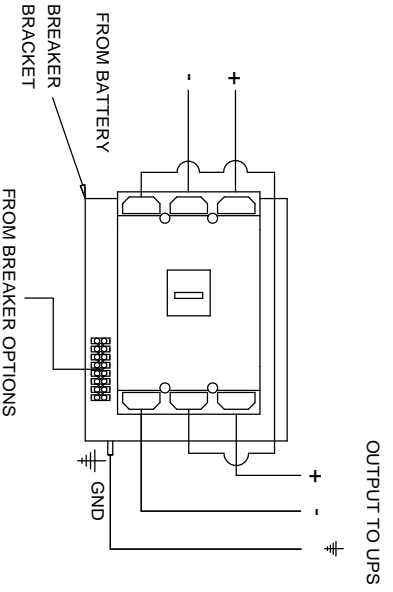

AUXILIARY CONTACTS LISTED APPLICABLE WHEN BREAKER IS IN THE CLOSED (ON) POSITION

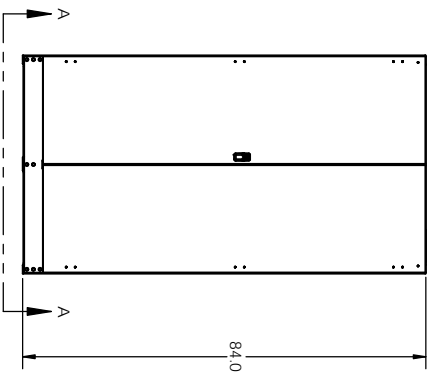
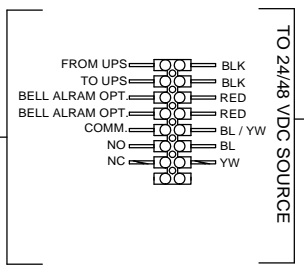

FRONT VIEW

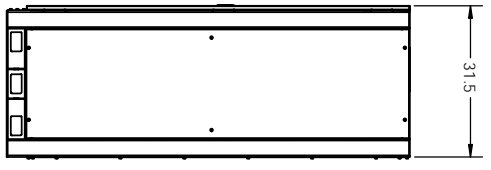

SIDE VIEW

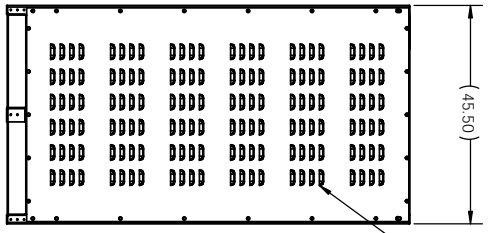

REAR VIEW

VENTILATION LOUVERS

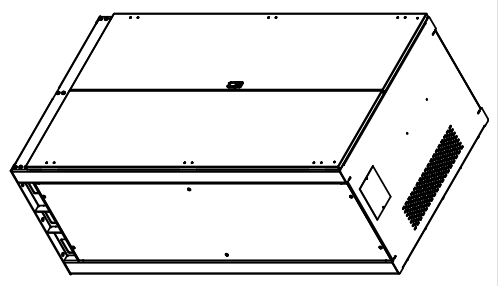

ISOMETRIC VIEW

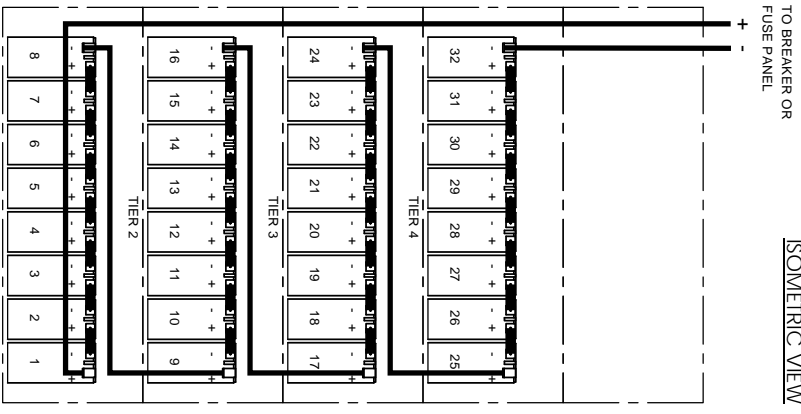

TYP 384V WIRING

PROHIBITARY AND CONFIDENTIAL
 THE INFORMATION CONTAINED IN THIS DOCUMENT IS UNCLASSIFIED EXCEPT WHERE SHOWN OTHERWISE. ANY REPRODUCTION OF THIS INFORMATION IS UNAUTHORIZED.
 ELECTRONIC SYSTEMS SUPPORT

DATE	TITLE	3233 W. Kingsley Rd. Garland, Texas 75041 PH. 972-772-2468 FAX 972-278-9844
NAME	ESS	
DATE	12-22-16	
NAME	RNA	
DATE	12-22-16	
UNITS CHARGED SPECIFIED	DWG. NO.	384V_32 BLOCs
DIMENSIONS ARE IN INCHES	DOC. NO.	012200
PROJECTION	DO NOT SCALE DRAWING	SHEET 1 OF 1
REV	A	



- CABINET NOTES:
1. NEMA 1 DESIGN
 2. EMPTY CABINET WEIGHT: 820 LBS. (370 KG)
 3. SEE TABLE FOR LOADED WEIGHTS.

BATTERY CABINET LOADED WEIGHTS	
BATTERY MODEL	WEIGHT (LBS)
EAST PENN - HR7500ET	5420

BREAKER DETAIL

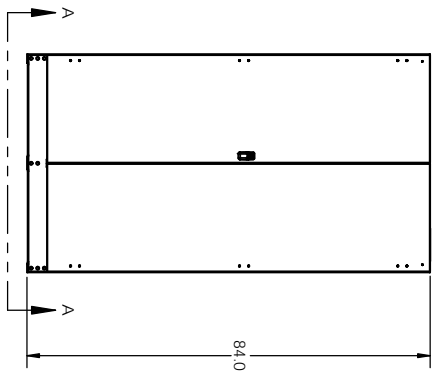
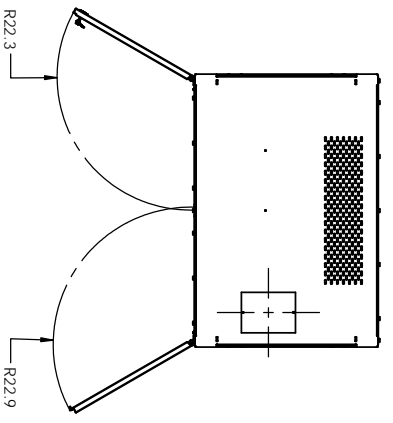

FRONT VIEW

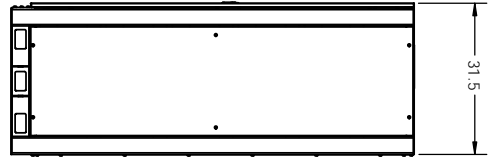

SIDE VIEW

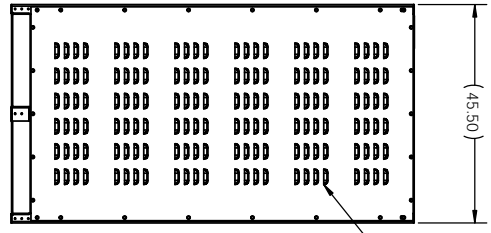

REAR VIEW

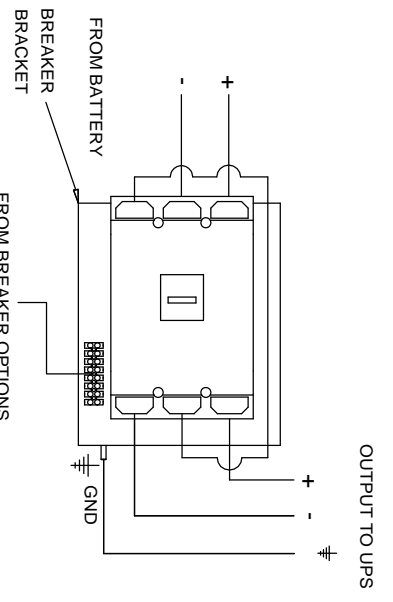

AUXILIARY CONTACTS LISTED APPLICABLE WHEN BREAKER IS IN THE CLOSED (ON) POSITION

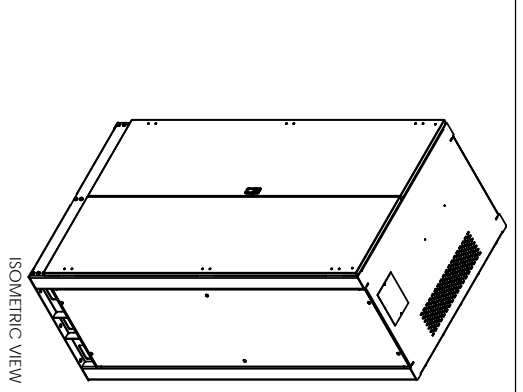

ISOMETRIC VIEW

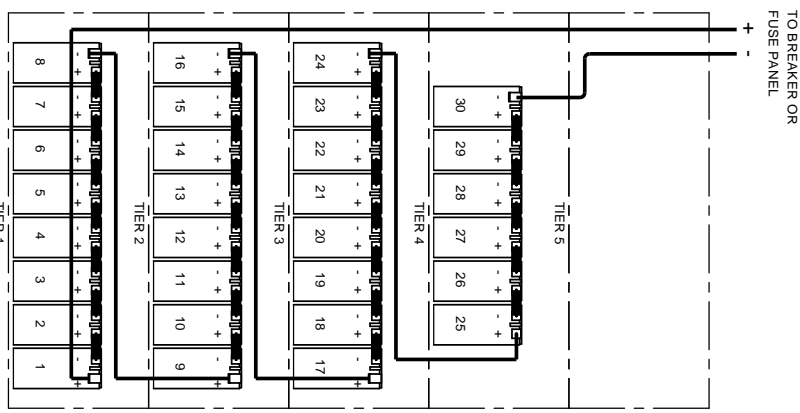

TYP 360V WIRING

PROHIBITARY AND CONFIDENTIAL
 THE INFORMATION CONTAINED IN THIS DOCUMENT IS UNCLASSIFIED EXCEPT WHERE SHOWN OTHERWISE. ANY REPRODUCTION OF THIS INFORMATION IS UNAUTHORIZED WITHOUT THE WRITTEN PERMISSION OF ELECTRONIC SYSTEMS SUPPORT, INC.

ESS ELECTRONIC SYSTEMS SUPPORT
 www.ess.io

3233 W. Kingsley Rd.
 Garland, Texas 75041
 PH: 972-272-2468
 FAX: 972-278-9844

DATE	TITLE
12-22-16	EFCS4 BATTERY CABINET
NAME	DWG. NO.
RJA	360V_30 BLOCs
DATE	REV
12-22-16	A

PROJECTION: DO NOT SCALE DRAWING. SHEET 1 OF 1



- CABINET NOTES:
1. NEMA 1 DESIGN
 2. EMPTY CABINET WEIGHT: 730 LBS. (332 KG)
 3. SEE TABLE FOR LOADED WEIGHTS.

BATTERY CABINET LOADED WEIGHTS	
BATTERY MODEL	WEIGHT (LBS)
EAST PENN - HR7500ET	5630

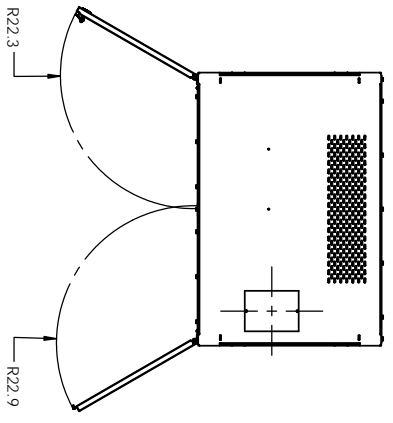

BREAKER DETAIL

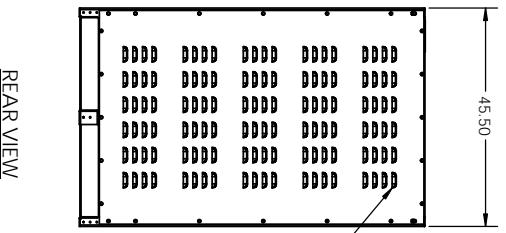
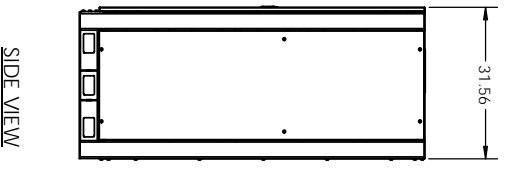
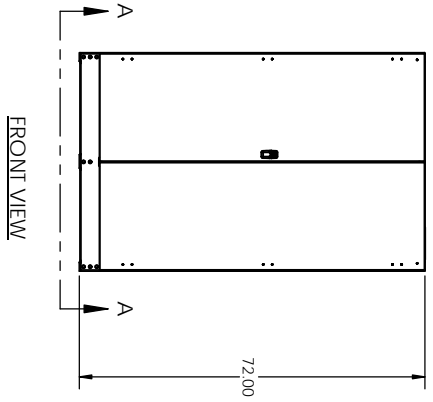
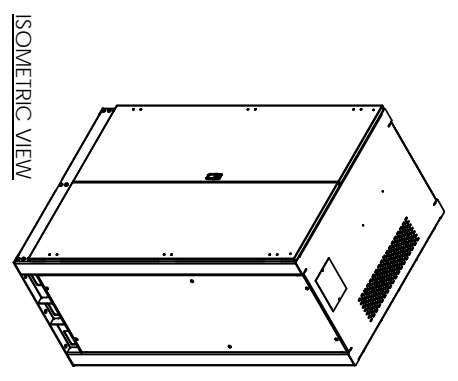
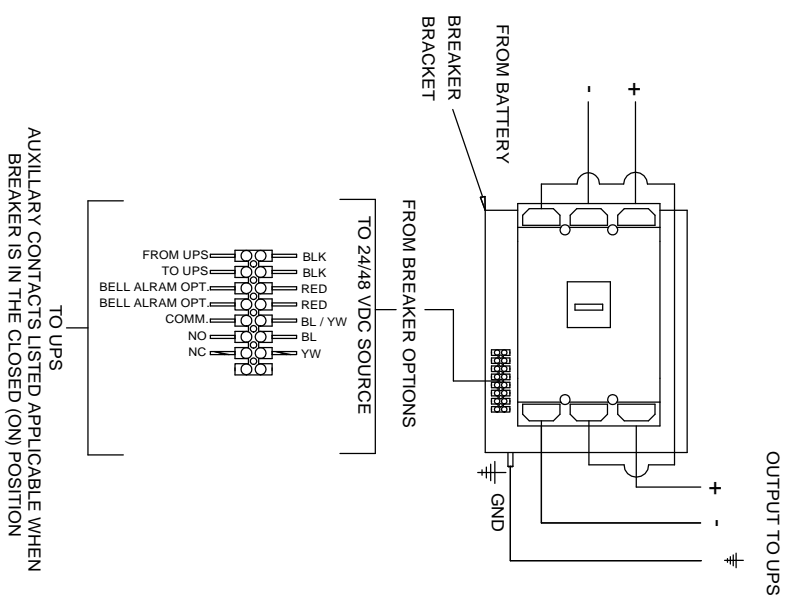

VENTILATION LOUVERS

TYP 384V WIRING

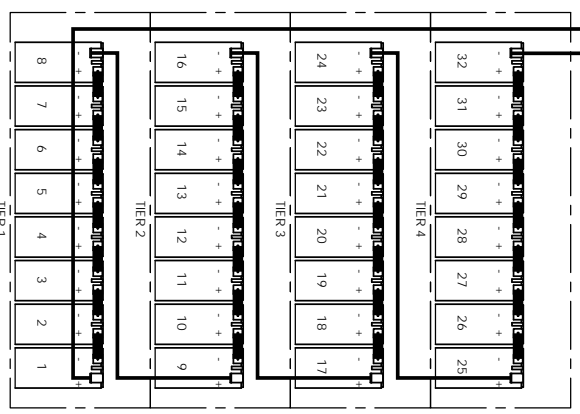

PROHIBITARY AND COMMERCIAL
 THE INFORMATION CONTAINED IN THIS DRAWING IS THE PROPERTY OF ESS. IT IS TO BE USED ONLY FOR THE PROJECT AND SITE SPECIFICALLY IDENTIFIED HEREIN. ANY REUSE OR MODIFICATION OF THIS DRAWING WITHOUT THE WRITTEN PERMISSION OF ESS IS PROHIBITED.

DATE	TITLE	3233 W. Kingsley Rd. Garland, Texas 75041 PH. 972-272-2468 FAX 972-276-9844
DATE	REV	
12-22-16	1	ESS ELECTRONIC SYSTEMS SUPPORT www.ess.io
12-22-16	2	ESS ELECTRONIC SYSTEMS SUPPORT www.ess.io
12-22-16	3	ESS ELECTRONIC SYSTEMS SUPPORT www.ess.io
12-22-16	4	ESS ELECTRONIC SYSTEMS SUPPORT www.ess.io
12-22-16	5	ESS ELECTRONIC SYSTEMS SUPPORT www.ess.io
12-22-16	6	ESS ELECTRONIC SYSTEMS SUPPORT www.ess.io
12-22-16	7	ESS ELECTRONIC SYSTEMS SUPPORT www.ess.io
12-22-16	8	ESS ELECTRONIC SYSTEMS SUPPORT www.ess.io
12-22-16	9	ESS ELECTRONIC SYSTEMS SUPPORT www.ess.io
12-22-16	10	ESS ELECTRONIC SYSTEMS SUPPORT www.ess.io
12-22-16	11	ESS ELECTRONIC SYSTEMS SUPPORT www.ess.io
12-22-16	12	ESS ELECTRONIC SYSTEMS SUPPORT www.ess.io
12-22-16	13	ESS ELECTRONIC SYSTEMS SUPPORT www.ess.io
12-22-16	14	ESS ELECTRONIC SYSTEMS SUPPORT www.ess.io
12-22-16	15	ESS ELECTRONIC SYSTEMS SUPPORT www.ess.io
12-22-16	16	ESS ELECTRONIC SYSTEMS SUPPORT www.ess.io
12-22-16	17	ESS ELECTRONIC SYSTEMS SUPPORT www.ess.io
12-22-16	18	ESS ELECTRONIC SYSTEMS SUPPORT www.ess.io
12-22-16	19	ESS ELECTRONIC SYSTEMS SUPPORT www.ess.io
12-22-16	20	ESS ELECTRONIC SYSTEMS SUPPORT www.ess.io
12-22-16	21	ESS ELECTRONIC SYSTEMS SUPPORT www.ess.io
12-22-16	22	ESS ELECTRONIC SYSTEMS SUPPORT www.ess.io
12-22-16	23	ESS ELECTRONIC SYSTEMS SUPPORT www.ess.io
12-22-16	24	ESS ELECTRONIC SYSTEMS SUPPORT www.ess.io
12-22-16	25	ESS ELECTRONIC SYSTEMS SUPPORT www.ess.io
12-22-16	26	ESS ELECTRONIC SYSTEMS SUPPORT www.ess.io
12-22-16	27	ESS ELECTRONIC SYSTEMS SUPPORT www.ess.io
12-22-16	28	ESS ELECTRONIC SYSTEMS SUPPORT www.ess.io
12-22-16	29	ESS ELECTRONIC SYSTEMS SUPPORT www.ess.io
12-22-16	30	ESS ELECTRONIC SYSTEMS SUPPORT www.ess.io
12-22-16	31	ESS ELECTRONIC SYSTEMS SUPPORT www.ess.io
12-22-16	32	ESS ELECTRONIC SYSTEMS SUPPORT www.ess.io
12-22-16	33	ESS ELECTRONIC SYSTEMS SUPPORT www.ess.io
12-22-16	34	ESS ELECTRONIC SYSTEMS SUPPORT www.ess.io
12-22-16	35	ESS ELECTRONIC SYSTEMS SUPPORT www.ess.io
12-22-16	36	ESS ELECTRONIC SYSTEMS SUPPORT www.ess.io
12-22-16	37	ESS ELECTRONIC SYSTEMS SUPPORT www.ess.io
12-22-16	38	ESS ELECTRONIC SYSTEMS SUPPORT www.ess.io
12-22-16	39	ESS ELECTRONIC SYSTEMS SUPPORT www.ess.io
12-22-16	40	ESS ELECTRONIC SYSTEMS SUPPORT www.ess.io
12-22-16	41	ESS ELECTRONIC SYSTEMS SUPPORT www.ess.io
12-22-16	42	ESS ELECTRONIC SYSTEMS SUPPORT www.ess.io
12-22-16	43	ESS ELECTRONIC SYSTEMS SUPPORT www.ess.io
12-22-16	44	ESS ELECTRONIC SYSTEMS SUPPORT www.ess.io
12-22-16	45	ESS ELECTRONIC SYSTEMS SUPPORT www.ess.io
12-22-16	46	ESS ELECTRONIC SYSTEMS SUPPORT www.ess.io
12-22-16	47	ESS ELECTRONIC SYSTEMS SUPPORT www.ess.io
12-22-16	48	ESS ELECTRONIC SYSTEMS SUPPORT www.ess.io
12-22-16	49	ESS ELECTRONIC SYSTEMS SUPPORT www.ess.io
12-22-16	50	ESS ELECTRONIC SYSTEMS SUPPORT www.ess.io
12-22-16	51	ESS ELECTRONIC SYSTEMS SUPPORT www.ess.io
12-22-16	52	ESS ELECTRONIC SYSTEMS SUPPORT www.ess.io
12-22-16	53	ESS ELECTRONIC SYSTEMS SUPPORT www.ess.io
12-22-16	54	ESS ELECTRONIC SYSTEMS SUPPORT www.ess.io
12-22-16	55	ESS ELECTRONIC SYSTEMS SUPPORT www.ess.io
12-22-16	56	ESS ELECTRONIC SYSTEMS SUPPORT www.ess.io
12-22-16	57	ESS ELECTRONIC SYSTEMS SUPPORT www.ess.io
12-22-16	58	ESS ELECTRONIC SYSTEMS SUPPORT www.ess.io
12-22-16	59	ESS ELECTRONIC SYSTEMS SUPPORT www.ess.io
12-22-16	60	ESS ELECTRONIC SYSTEMS SUPPORT www.ess.io
12-22-16	61	ESS ELECTRONIC SYSTEMS SUPPORT www.ess.io
12-22-16	62	ESS ELECTRONIC SYSTEMS SUPPORT www.ess.io
12-22-16	63	ESS ELECTRONIC SYSTEMS SUPPORT www.ess.io
12-22-16	64	ESS ELECTRONIC SYSTEMS SUPPORT www.ess.io
12-22-16	65	ESS ELECTRONIC SYSTEMS SUPPORT www.ess.io
12-22-16	66	ESS ELECTRONIC SYSTEMS SUPPORT www.ess.io
12-22-16	67	ESS ELECTRONIC SYSTEMS SUPPORT www.ess.io
12-22-16	68	ESS ELECTRONIC SYSTEMS SUPPORT www.ess.io
12-22-16	69	ESS ELECTRONIC SYSTEMS SUPPORT www.ess.io
12-22-16	70	ESS ELECTRONIC SYSTEMS SUPPORT www.ess.io
12-22-16	71	ESS ELECTRONIC SYSTEMS SUPPORT www.ess.io
12-22-16	72	ESS ELECTRONIC SYSTEMS SUPPORT www.ess.io
12-22-16	73	ESS ELECTRONIC SYSTEMS SUPPORT www.ess.io
12-22-16	74	ESS ELECTRONIC SYSTEMS SUPPORT www.ess.io
12-22-16	75	ESS ELECTRONIC SYSTEMS SUPPORT www.ess.io
12-22-16	76	ESS ELECTRONIC SYSTEMS SUPPORT www.ess.io
12-22-16	77	ESS ELECTRONIC SYSTEMS SUPPORT www.ess.io
12-22-16	78	ESS ELECTRONIC SYSTEMS SUPPORT www.ess.io
12-22-16	79	ESS ELECTRONIC SYSTEMS SUPPORT www.ess.io
12-22-16	80	ESS ELECTRONIC SYSTEMS SUPPORT www.ess.io
12-22-16	81	ESS ELECTRONIC SYSTEMS SUPPORT www.ess.io
12-22-16	82	ESS ELECTRONIC SYSTEMS SUPPORT www.ess.io
12-22-16	83	ESS ELECTRONIC SYSTEMS SUPPORT www.ess.io
12-22-16	84	ESS ELECTRONIC SYSTEMS SUPPORT www.ess.io
12-22-16	85	ESS ELECTRONIC SYSTEMS SUPPORT www.ess.io
12-22-16	86	ESS ELECTRONIC SYSTEMS SUPPORT www.ess.io
12-22-16	87	ESS ELECTRONIC SYSTEMS SUPPORT www.ess.io
12-22-16	88	ESS ELECTRONIC SYSTEMS SUPPORT www.ess.io
12-22-16	89	ESS ELECTRONIC SYSTEMS SUPPORT www.ess.io
12-22-16	90	ESS ELECTRONIC SYSTEMS SUPPORT www.ess.io
12-22-16	91	ESS ELECTRONIC SYSTEMS SUPPORT www.ess.io
12-22-16	92	ESS ELECTRONIC SYSTEMS SUPPORT www.ess.io
12-22-16	93	ESS ELECTRONIC SYSTEMS SUPPORT www.ess.io
12-22-16	94	ESS ELECTRONIC SYSTEMS SUPPORT www.ess.io
12-22-16	95	ESS ELECTRONIC SYSTEMS SUPPORT www.ess.io
12-22-16	96	ESS ELECTRONIC SYSTEMS SUPPORT www.ess.io
12-22-16	97	ESS ELECTRONIC SYSTEMS SUPPORT www.ess.io
12-22-16	98	ESS ELECTRONIC SYSTEMS SUPPORT www.ess.io
12-22-16	99	ESS ELECTRONIC SYSTEMS SUPPORT www.ess.io
12-22-16	100	ESS ELECTRONIC SYSTEMS SUPPORT www.ess.io



CABINET NOTES:

1. NEMA 1 DESIGN
2. EMPTY CABINET WEIGHT: 730 LBS (332 KG)
3. SEE TABLE FOR LOADED WEIGHTS.

BATTERY CABINET LOADED WEIGHTS	
BATTERY MODEL	WEIGHT (LBS)
EAST PENN - HR7500ET	4430

BREAKER DETAIL

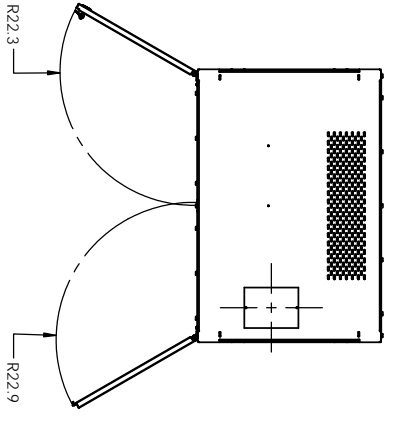
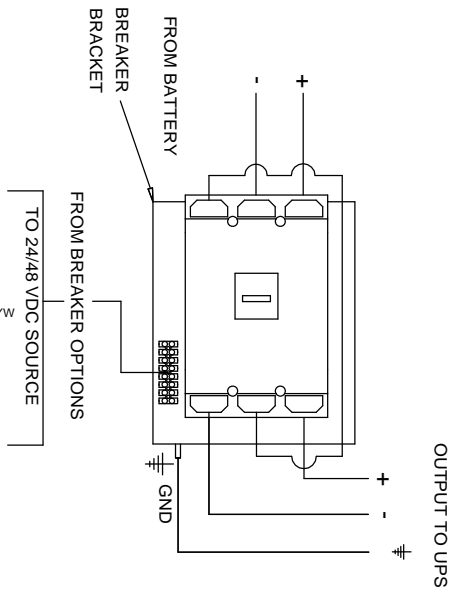

AUXILIARY CONTACTS LISTED APPLICABLE WHEN BREAKER IS IN THE CLOSED (ON) POSITION

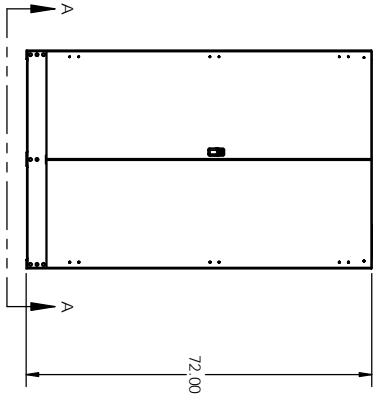
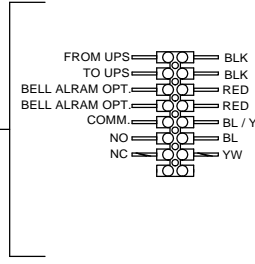

FRONT VIEW

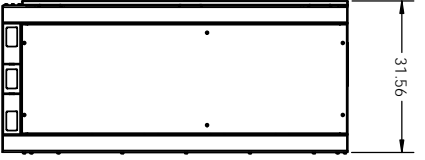

SIDE VIEW

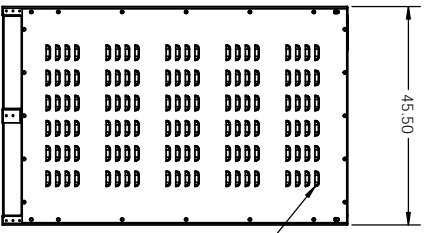

REAR VIEW

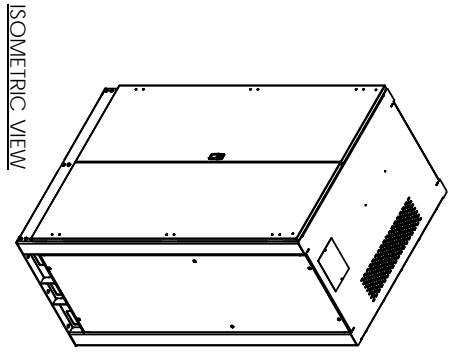

ISOMETRIC VIEW

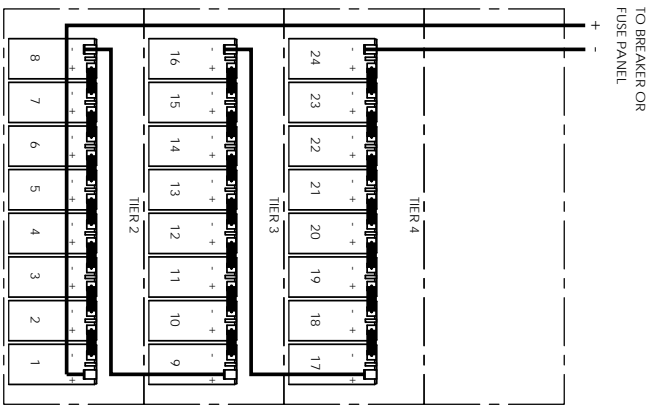

PROHIBITARY AND CONFIDENTIAL

THE INFORMATION CONTAINED IN THIS DRAWING IS THE PROPERTY OF ESS. IT IS TO BE USED FOR THE PROJECT AND SITE SPECIFICALLY IDENTIFIED HEREIN. ANY REUSE OR MODIFICATION OF THIS INFORMATION WITHOUT THE WRITTEN PERMISSION OF ESS IS PROHIBITED.

DATE	12-22-16	TITLE	ESS ELECTRONIC SYSTEMS SUPPORT
DESIGNER	RNA	DWG. NO.	EFC44 BATTERY CABINET
CHECKED	RNA	DOC. NO.	288V, 24 BLOCs
DATE	12-22-16	PROJECT	DO NOT SCALE DRAWING

3233 W. Kingsley Rd.
Garland, Texas 75041
PH: 972-722-2468
FAX: 972-278-9844

ESS ELECTRONIC SYSTEMS SUPPORT
www.ess.io

PROJECTION: SHEET 1 OF 1

- CABINET NOTES:
- NEMA 1 DESIGN.
 - EMPTY CABINET WEIGHT: 875 LBS (397 KG)
 - SEE TABLE FOR LOADED WEIGHTS.

BATTERY CABINET LOADED WEIGHTS	WEIGHT (LBS)
BATTERY MODEL	
EAST PENN - HR7500ET	6975

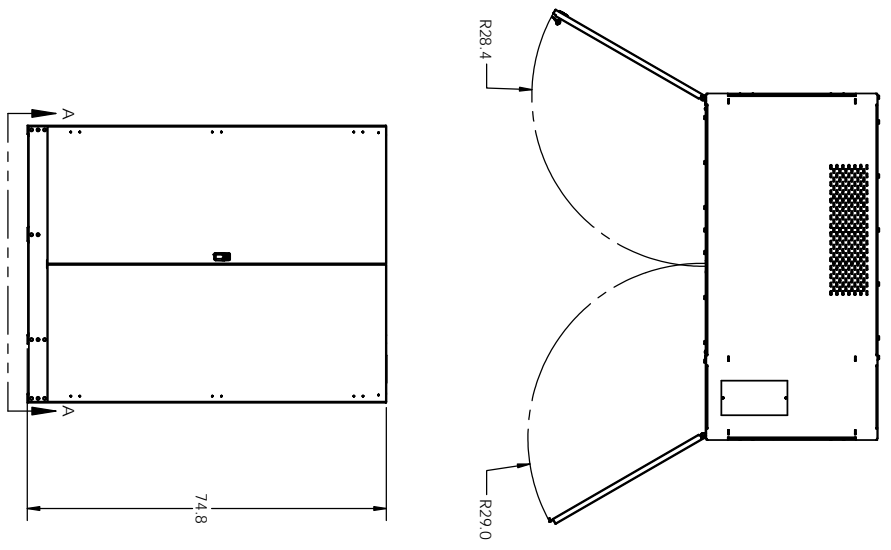

FRONT VIEW

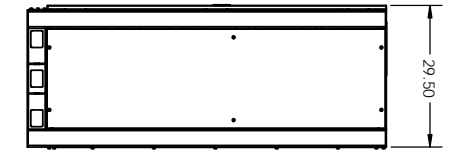

SIDE VIEW

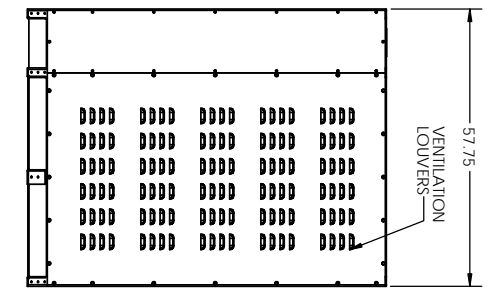

REAR VIEW

BREAKER DETAIL

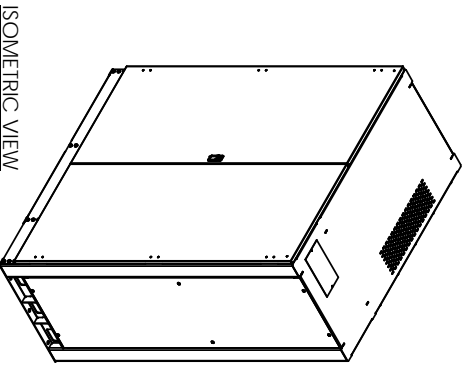
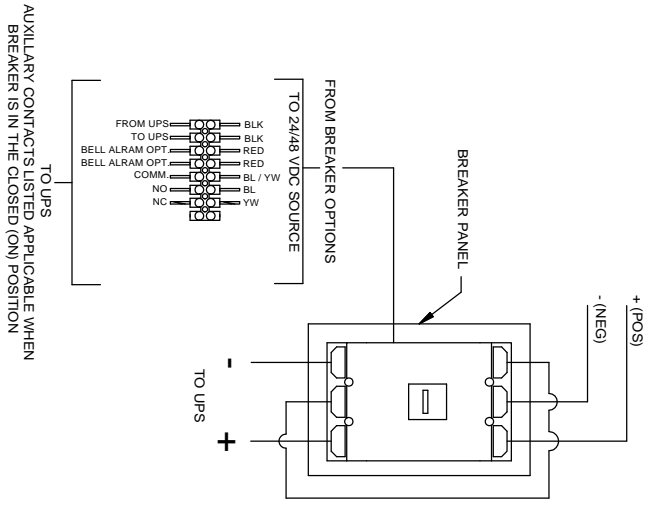

ISOMETRIC VIEW

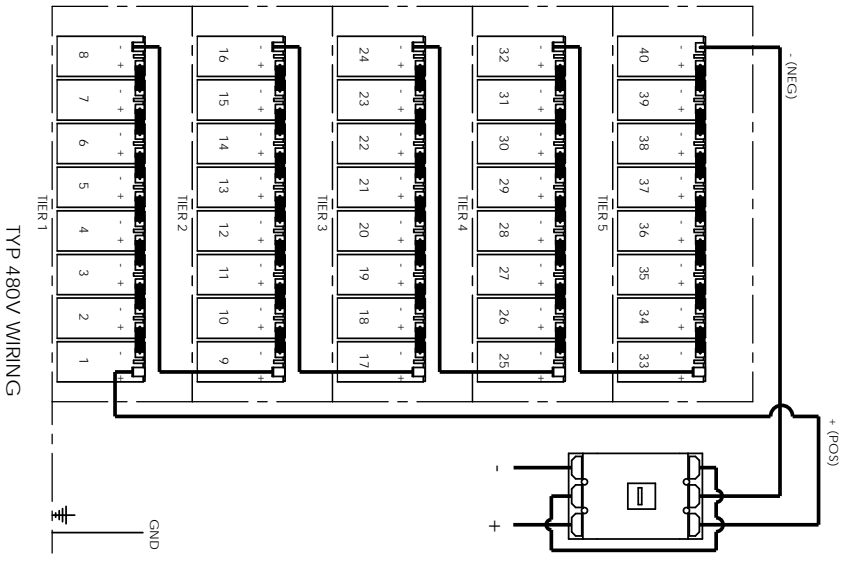

PROHIBITARY AND CONFIDENTIAL
 THE INFORMATION CONTAINED IN THIS DOCUMENT IS UNCLASSIFIED EXCEPT WHERE SHOWN OTHERWISE AND IS NOT TO BE RELEASED OR DISSEMINATED WITHOUT THE WRITTEN PERMISSION OF THE ORIGINAL SOURCE.
ESS ELECTRONIC SYSTEMS SUPPORT
 www.ess.io

3233 W. Kingsley Rd
 Garland, Texas 75041
 PH: 972-272-2468
 FAX: 972-276-9844

NAME:	ESS	TITLE:	ESS-4 BATTERY CABINET
DATE:	12-22-16	DATE:	12-22-16
DRAWN:	RNU	APPR:	RVA
DESIGNED:	RVA	CHECKED:	RVA
UNLESS OTHERWISE SPECIFIED		DWG. NO.	DOC-012600
DIMENSIONS ARE IN INCHES		REV	A
PROJECTION:		DO NOT SCALE DRAWING	SHEET 1 OF 1



- CABINET NOTES:
- NEMA 1 DESIGN
 - EMPTY CABINET WEIGHT: 875 LBS (397 KG)
 - SEE TABLE FOR LOADED WEIGHTS

BATTERY CABINET LOADED WEIGHTS	
BATTERY MODEL	WEIGHT (LBS)
EAST PENN - HR7500ET	5775

BREAKER DETAIL

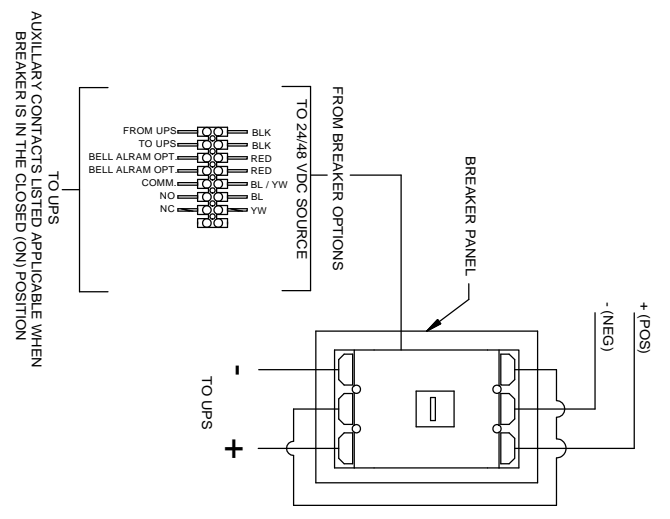

ISOMETRIC VIEW

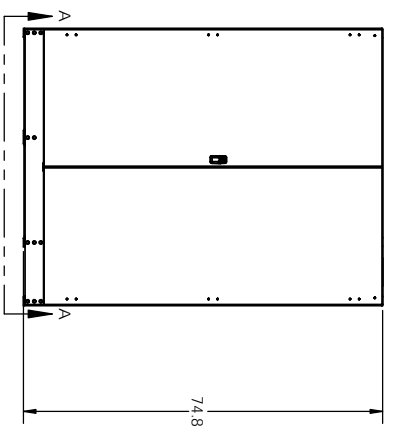
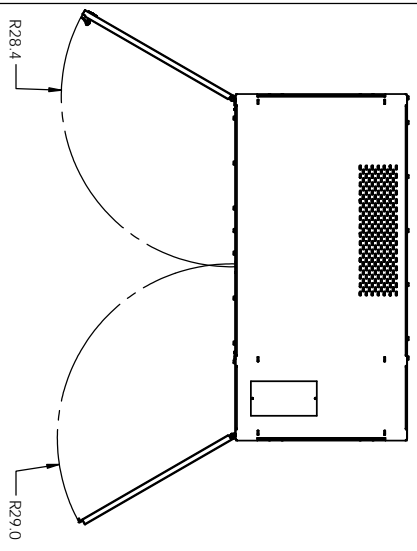
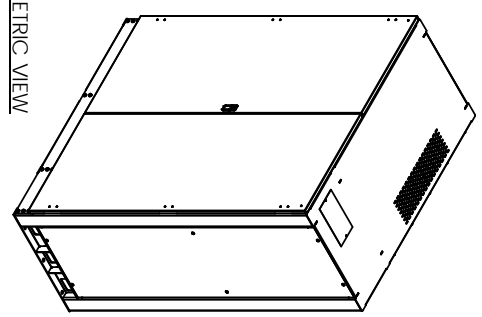

FRONT VIEW

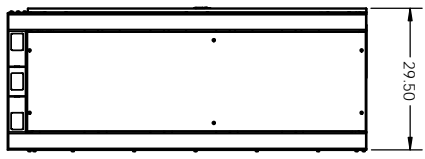

SIDE VIEW

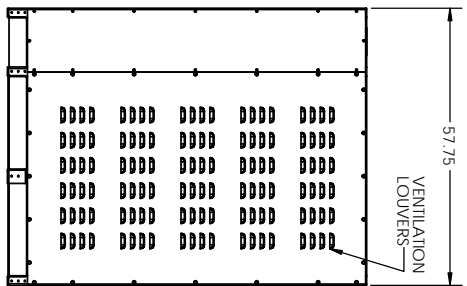

REAR VIEW

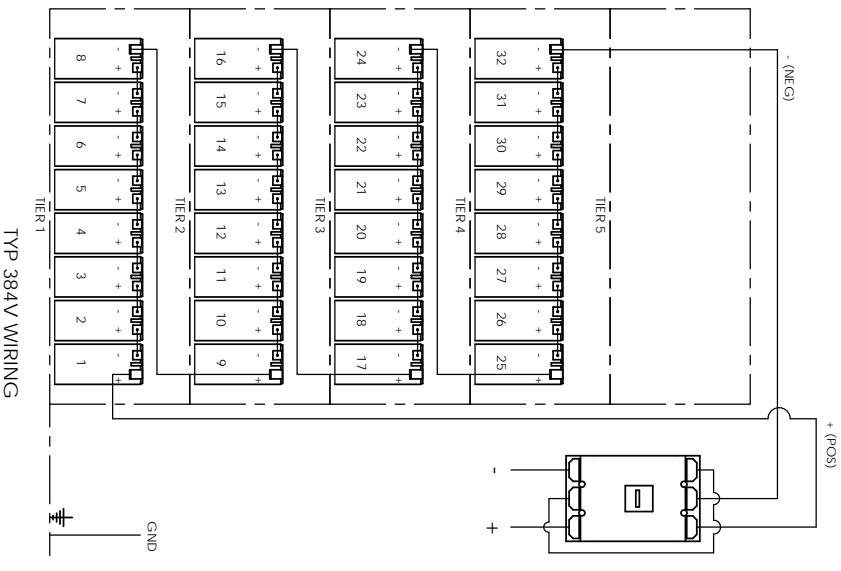

TYP 384V WIRING

PROHIBITARY AND COMMERCIAL

THE INFORMATION CONTAINED IN THIS DRAWING IS THE PROPERTY OF ESS. IT IS TO BE USED FOR THE PROJECT AND SITE SPECIFICALLY IDENTIFIED HEREIN. ANY REUSE OR MODIFICATION OF THIS INFORMATION WITHOUT THE WRITTEN PERMISSION OF ESS IS PROHIBITED.

NAME:	DATE:	TITLE:
ESS	12-22-16	ESS54 BATTER CABINET
DESIGNER:	DATE:	PROJECT:
ESS	12-22-16	DO NOT SCALE DRAWING
CHECKER:	DATE:	SHEET:
ESS	12-22-16	1 OF 1

3233 W. Kingsley Rd.
Garland, Texas 75041
PH: 972-272-2468
FAX: 972-276-9844

www.ess.io



- CABINET NOTES:
- NEMA 1 DESIGN.
 - EMPTY CABINET WEIGHT: 584 LBS. (264 KG)
 - SEE TABLE FOR LOADED WEIGHTS.

BATTERY MODEL	WEIGHT (LBS)
ENERSYS - 12XE1010F-FR	3894
ENERSYS - 12XE1110F-FR	4104
ENERSYS - 12XE1150F-FR	4554
EAST PENN - HR8300ET	3084
EAST PENN - HR8500ET	4284
C&D - UPS12-335WRF	3084
C&D - UPS12-615WRF	4134
C&D - UPS12-700WRF	4614
C&D - UPS12-410WRF	3138
C&D - UPS12-1000WRF	6512
NORTHSTAR - NSB12-450RT	3294
NORTHSTAR - NSB12-650RT	4224
NORTHSTAR - NSB12-730RT	4794
NORTHSTAR - NSB155FT	4314
NORTHSTAR - NSB170FT	4644
NORTHSTAR - NSB190FT	4794
NORTHSTAR - NSB210FT	5244
GNB - S12V645FT	4374
GNB - S12V735FT	4854

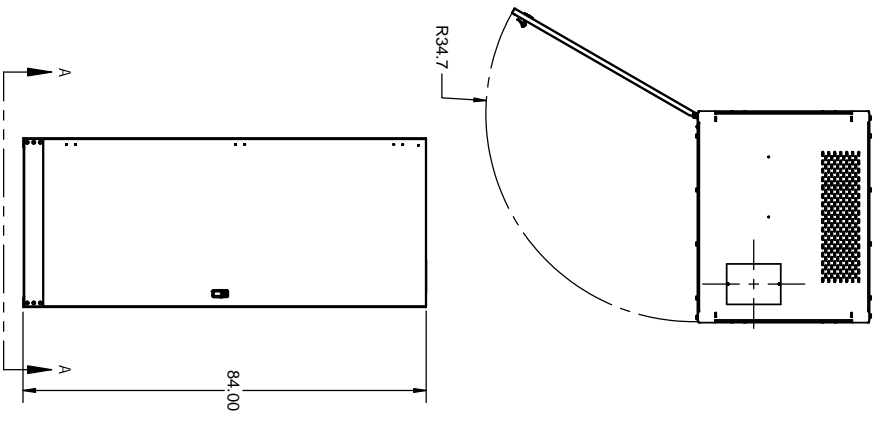

BREAKER DETAIL

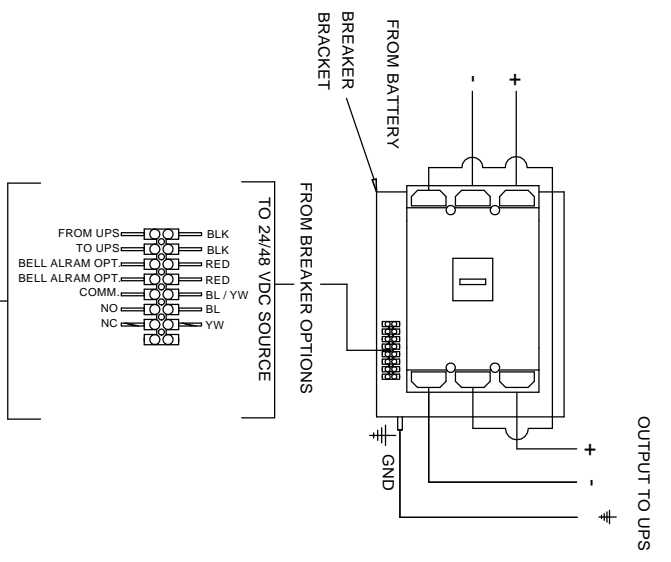

AUXILIARY CONTACTS LISTED APPLICABLE WHEN BREAKER IS IN THE CLOSED (ON) POSITION

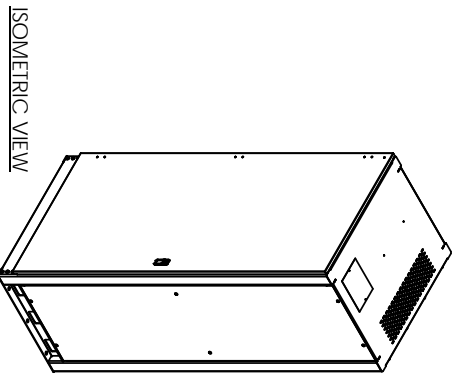

ISOMETRIC VIEW

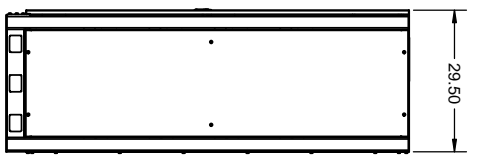

SIDE VIEW

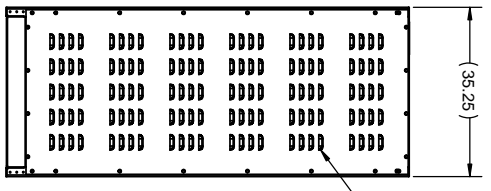

VENTILATION LOUVERS

REAR VIEW

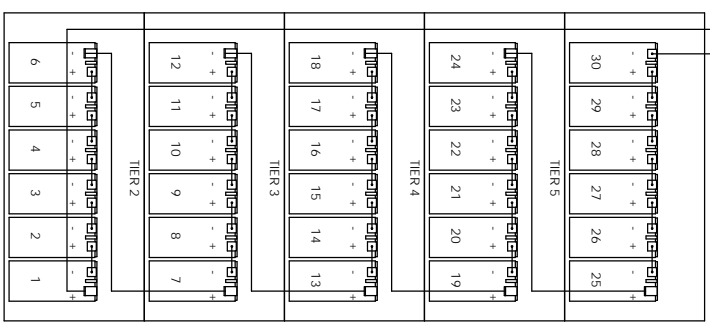

TYP 360VDC WIRING

PROHIBITARY AND CONFIDENTIAL

THE INFORMATION CONTAINED IN THIS DRAWING IS THE PROPERTY OF ESS ELECTRONIC SYSTEMS SUPPORT. ANY REPRODUCTION OR TRANSMISSION OF THIS INFORMATION WITHOUT THE WRITTEN PERMISSION OF ESS ELECTRONIC SYSTEMS SUPPORT IS PROHIBITED.

ESS ELECTRONIC SYSTEMS SUPPORT
www.ess.io

3233 W. Kingsley Rd.
Garland, Texas 75041
PH: 972-272-2468
FAX: 972-278-9848

DATE:	01-06-17	TITLE:	ECFS1 BATTERY CABINET
DESIGNER:	RVA	DWG. NO.:	DOC-013300
DATE:	01-06-17	REVISIONS:	
DATE:		REVISIONS:	

PROJECTION: DO NOT SCALE DRAWING. SHEET 1 OF 1



NOTES



3233 W. Kingsley Rd. • Garland, TX 75041 • Ph: 972-272-2468 • Fax: 972-272-276-9844 • www.ess.to