

EFC63/EFC53

BATTERY CABINET

INSTALLATION, OPERATION, AND MAINTENANCE MANUAL



This manual provides instructions regarding safety, storage, installation, operation and maintenance. Failure to observe the precautions as presented may result in injury or loss of life.

This document is proprietary to Electronic Systems Support (ESS). This document cannot be copied or reproduced in whole or in part, nor can its contents be revealed in any manner or to any person except to meet the purpose for which it was delivered, without the express written permission of Electronic Systems Support.

Please visit ess.to to check for updates to manual.



TABLE OF CONTENTS

1. INTRODUCTION	2
2. PRECAUTIONS.....	2
3. INSPECTION UPON RECEIPT OF GOODS	3
3.1 General	3
3.2 Visible damage	3
3.3 Concealed damage	3
3.4 Return of damaged goods	3
4. SYSTEM OVERVIEW	3
5. GENERAL SYSTEM SPECIFICATIONS.....	4
5.1 DC Output Characteristics	4
5.2 Batteries.....	4
5.3 Grounding.....	4
5.4 Environmental Conditions.....	4
• Cabinet Dimensions	4
• Cabinet Weights (Assembled)	5
6. INSTALLATION PROCEDURES.....	5
6.1 Preparation	5
6.1.1 Necessary Equipment and Tools	5
6.1.2 Equipment Inspection	5
6.1.3 Safety Precautions	6
7. INSTALLATION STEPS	6
7.1 Cabinet Location.....	6
7.2 Cabinet Mounting	6
7.3 DC Connections	7
7.4 Grounding.....	7
7.5 System Operation	7
8. SYSTEM MAINTENANCE.....	8
8.1 Blown Fuse Replacement.....	8
8.2 Battery Replacement Steps.....	8
9. WARRANTY RELATED MAINTENANCE	
10. DRAWINGS/SCHEMATICS	10
• General Cabinet Drawing.....	10
• Anchor Specifications	11
• Anchor Placement Dimensions.....	12
• 492V, EFC63, 7 x 6, Top Breaker – Mechanical / Electrical Drawing	13
• 480V, EFC63, 7 x 6, Top Breaker – Mechanical / Electrical Drawing	14
• 432V, EFC63, 6 x 6, Top Breaker – Mechanical / Electrical Drawing	15
• 384V, EFC63, 6 x 6, Top Breaker – Mechanical / Electrical Drawing	16
• 360V, EFC63, 6 x 6, Top Breaker – Mechanical / Electrical Drawing	17
• 288V, EFC63, 4 x 6, Top Breaker – Mechanical / Electrical Drawing	18
• 480V, EFC53, 8 x 5, Top Breaker – Mechanical / Electrical Drawing	19
• 432V, EFC53, 8 x 5, Top Breaker – Mechanical / Electrical Drawing	20
• 384V, EFC53, 8 x 5, Top Breaker – Mechanical / Electrical Drawing	21
• 360V, EFC53, 8 x 5, Top Breaker – Mechanical / Electrical Drawing	22
• 288V, EFC53, 8 x 5, Top Breaker – Mechanical / Electrical Drawing	23
• Notes Page	24
• Notes Page	25











1. INTRODUCTION

ESS EFC63/EFC53 Front Terminal Battery Cabinets are shipped partially assembled, internally pre-wired and come standard with an over current breaker. The removable hinged front doors and removable rear cover also allow for easier battery access. Maintenance rear covers are not needed since all batteries come with nylon straps for easier lifting and moving. Refer to the battery layout drawings and schematics at the end of this manual. Consult the battery manufacturer's battery operation and maintenance manual for complete instructions.

These battery systems are Hi-Pot tested to UL 1778 standards at the factory prior to shipment. All system settings are also adjusted at this time according to the specification sheet. Sales support for future equipment or upgrades is provided by our sales staff and qualified representatives. All technical questions and service issues should be directed to our office 972-272-2468.

2. PRECAUTIONS

-  **It is very important to read, understand and follow the instructions in this manual. Also note all SAFETY PRECAUTIONS before beginning the installation of this system.**
-  **Consult the Battery Manufacturer's Operation and Maintenance Manual for important battery information.**
-  **Battery cabinet systems are very heavy. Total weight can exceed 7,150 lbs, while single cabinets can weigh up to 4,010 lbs. Use at least 3 people when unloading and setting equipment in place.**
-  **It is imperative that only qualified personnel work on this system and installation, maintenance or upgrades be performed with insulated tools and equipment.**
-  **When installing this battery system, follow all applicable federal, state and local regulations and industry guidelines to insure a proper installation.**
-  **DC power and battery supplies are dangerous and have extremely high short circuit currents. Severe burns or death can result from a system short. They also can leak potentially explosive gas (hydrogen). Never enclose batteries or battery cabinets in a sealed air tight room.**
-  **All jewelry and watches must be removed prior to installing or servicing this system.**
-  **Do not smoke or present flame near or around any battery cabinet system.**
-  **Never leave a panel off or door open and unattended.**

3. INSPECTION UPON RECEIPT OF GOODS

3.1 General

Special precautions and care have been taken to ensure the cabinet system arrives safe and undamaged. However, upon receipt, you should inspect the entire shipment, including the crate and any boxes for evidence of damage that may have occurred during transit.



3.2 Visible Damage

It is the responsibility of the person receiving the shipment to inventory and fully inspect all materials against the bill of lading or way bill IMMEDIATELY, while the carrier representative is still present. Ensure that all items are accounted for, including number of skids and quantity of boxes. Also note any visible external damage that may have occurred during transit. Make all applicable notations on the delivery receipt before signing and file a damage report with the carrier.

3.3 Concealed Damage

Within 30 days of receipt, unpack the cabinet system and check for any concealed damage. Check the materials received against the detailed packing list to verify the quantity and the condition as complete and satisfactory.

Note any damage to the internal packaging, then request an inspection by the carrier and file a concealed damage claim. If there is a material shortage, contact ESS at the number listed at the end of this manual.

Please contact your shipping company for all shipping damage. ESS is not responsible for any shipping damage.

3.4 Return of Damaged Goods

A RMA number must be obtained before returning equipment to ESS. Please contact an ESS representative or call the corporate number listed at the end of this manual.

4. SYSTEM OVERVIEW

The enclosed cabinet systems provide the necessary DC backup power required in UPS applications. Over-current breaker/fuse protection is supplied. DC connections are front accessible and made via terminal blocks and/or mechanical lugs. Refer to the drawings and schematics at the end of this manual for these connections. Cabinets are equipped with 3-pole breakers. There are 2 holes per polarity on 300 Amp to 600 Amp breakers. Breakers 30 Amps to 250 Amps have a single hole per polarity. **See table below for standard output lug sizes of breakers.**

BREAKER SIZING						
BREAKER SIZE AMPS	30A	40A	50A	75A	100A	125A
A.I.C. RATING, 500DC	20,000 A.I.C	20,000 A.I.C	20,000 A.I.C	20,000 A.I.C	20,000 A.I.C	20,000 A.I.C
OUTPUT LUG SIZE	(1)#14-3/0	(1)#14-3/0	(1)#14-3/0	(1)#14-3/0	(1)#14-3/0	(1)#4-3/0
BREAKER SIZE AMPS	150A	175A	200A	225A	250A	300A
A.I.C. RATING, 500DC	20,000 A.I.C	20,000 A.I.C	20,000 A.I.C	20,000 A.I.C	20,000 A.I.C	20,000 A.I.C
OUTPUT LUG SIZE	(1)#4-4/0	(1)#4-4/0	(1)3/0-350	(1)3/0-350	(1)3/0-350	(2) 2/0-500
BREAKER SIZE AMPS	350A	400A	450A	500A	600	
A.I.C. RATING, 500DC	20,000 A.I.C	20,000 A.I.C	20,000 A.I.C	20,000 A.I.C	20,000 A.I.C	
OUTPUT LUG SIZE	(2) 2/0-500	(2) 2/0-500	(2) 2/0-500	(2) 2/0-500	(2) 2/0-500	

During normal conditions the UPS supplies the load power and the necessary power required to keep the batteries at the proper float voltage. Verify that the charger is set to charge parameters within the approved float voltage range of the batteries, refer to manufacturer's battery operation and maintenance manual.

When AC fails, the batteries discharge in order to provide the necessary backup power. It is the responsibility of the customer to make sure the batteries are not discharged below the battery manufacturer's recommendations. Always recharge batteries per manufacturer's battery operation and maintenance manual. Batteries will be damaged if not recharged right away. See the UPS or DC system manual for more information.

5. GENERAL SYSTEM SPECIFICATIONS



5.1 DC Output Characteristics

- **Voltage:** (UPS Application) 120 to 492 VDC Nominal
- **Breaker:** Standard
- **Fuse Type:** Not standard, consult factory. If a fuse is provided, it is only to be replaced by a factory service technician.

CAUTION! Fire Hazard Warning:
Replace only with same type and rating of fuses supplied with the system.

- **Wire Size and Type:** Per NEC and/or local building and electrical codes.
- **Disconnect:** If a fuse has been provided in lieu of a breaker inside the cabinet, a disconnecting method must be provided per NEC code. This may be a fuse switch or circuit breaker. Size accordingly.

5.2 Batteries

- **Type:** Valve Regulated Lead Acid (VRLA), sealed, non-spillable.
- **Voltage:** 12 Volt DC Nominal, Front Terminal Design.

UL approved battery models:

Energys - 12HX680F-FR

East Penn - 4DHR6500

C&D - UPS12-745MRF

Interstate - 12MJ4500F

- **Only cabinets with flame retardant batteries are suitable for computer room use!**

5.3 Grounding

- All grounding should be derived from the main building ground source.
- **Note:** All cabinet systems require grounding.

5.4 Environmental Conditions

The cabinet system description refers to “X wide” x “Y high”, this is the number of battery jars per shelf and the number of shelves high. For example: a 7x6 cabinet system has 7 battery jars per shelf and the cabinet is 6 shelves high. 492 Vdc, 480 Vdc, and 384 Vdc cabinet systems are divided into (2 ea.) cabinets, one “Right” and one “Left”, to keep the weight of each cabinet below 5,500 lbs. Breakers are located at the top of the left cabinet and the dimensions vary accordingly.

Cabinet Dimensions:

EFC63, 7x6, Top Breaker is 67.5” W x 28.0” D* x 84.0” H (Consists of one 4 x 6 and one 3 x 6 cabinets)

EFC63, 6x6, Top Breaker is 59.0” W x 28.0” D* x 84.0” H (Consists of two 3 x 6 cabinets)

EFC53, 8x5, Top Breaker is 76.0” W x 28.0” D* x 78.7” H (Consists of two 4 x 5 cabinets)

EFC53, 8x4, Top Breaker is 76.0” W x 28.0” D* x 78.7” H (Consists of two 4 x 5 cabinets, top tier empty)

* All depth dimensions are of the cabinet only. The breaker handle (optional) extends from the front of the cabinet 2.25”; consider this distance when calculating aisle space in front of the cabinet.

For mounting hole dimensions, please refer to the cabinet layout drawing at the end of this manual. Also included with each order is a floor template to mark anchor locations per cabinet.



Max Cabinet Weights: (Assembled)

	VDC	# of Blocs
EFC63, 7x6, Top Breaker is 7,300 lbs.	492	41
EFC63, 7x6, Top Breaker is 7,150 lbs.	480	40
EFC63, 6x6, Top Breaker is 6,500 lbs.	432	36
EFC63, 6x6, Top Breaker is 5,880 lbs.	384	32
EFC63, 6x6, Top Breaker is 5,880 lbs.	360	30
EFC63, 4x6, Top Breaker is 4,450 lbs.	288	24
EFC53, 8x5, Top Breaker is 7,160 lbs.	480	40
EFC53, 8x5, Top Breaker is 6,540 lbs.	432	36
EFC53, 8x5, Top Breaker is 5,945 lbs.	384	32
EFC53, 8x5, Top Breaker is 5,635 lbs.	360	30
EFC53, 8x5, Top Breaker is 4,750 lbs.	288	24

- **Temperature:** Normal operating temperatures are between 68°F -77°F. **Note:** Batteries typically should be at 77°F for optimum battery life and performance.
- **Ventilation/Cooling:** Provided through ventilation slots in the rear panel, bottom panel, front door and top of cabinet, thus providing a chimney effect for natural convection cooling. If local codes require forced air exhaust, unused covers serve as conduit entry or duct work entry points.
- **Clearance:** A minimum of four inches is required in both the front and the rear of the cabinet. This refers to obstruction of ventilation only. Clearance around cabinet sides is suggested by NEC and local codes.

CAUTION! Explosion/Fire Hazard Warning:
Batteries can generate potentially explosive gas (hydrogen).
Never enclose batteries or battery cabinets in a sealed, airtight room.

6. INSTALLATION PRODEDURES

BEFORE PROCEEDING WITH INSTALLATION READ THE FOLLOWING:

6.1 Preparation

6.1.1 Necessary Equipment and Tools

- Rigging tools for moving cabinets. Narrow pallet jack and forklift of 5,500 lbs. minimum capacity.
- Heavily insulated assortment of hand tools.
- Digital Voltmeter

6.1.2 Equipment Inspection

Remove the packaging material from the cabinet and inspect for any concealed shipping damage that may have been overlooked upon receipt of goods. Use the packing list to verify the system has all components and cables for installation.













6.1.3 Safety Precautions

DC VOLTAGE WARNING!

Hazardous DC Voltages are present in the battery cabinet. This hazard will always be present, even when the battery system is off-line. Accidental short circuit of the positive and negative terminals will cause tremendous currents to flow resulting in severe burns, fire and possible death. Use extreme caution!

IMPORTANT SAFETY INSTRUCTIONS. SAVE THESE INSTRUCTIONS!!

-  All disconnecting means should be in the open/off position before servicing.
-  All installation drawings and schematics should be reviewed and clearly understood before hooking up this system.
-  Only qualified DC power technicians or electricians should attempt to work on and install this equipment.
-  All jewelry, rings and watches should be removed when working on this equipment.
-  All tool handles and shafts must be heavily insulated.
-  Do not rest any tools or loose cables on top of batteries.
-  Make sure all connections are properly torqued and secure. Torque values are provided on battery label.
-  Do not smoke or present flames near or around any battery system.
-  Always wear safety glasses and gloves and use insulating mats to stand on when working on this system.
-  Do not allow bare skin to come into contact with battery cabinet, as this could result in an electrical shock.
-  Do not install any cable terminations until it has been verified that such a termination will not create a short circuit.

7. INSTALLATION STEPS

7.1 Cabinet Location

Prior to installation, verify floor loading requirements and all applicable codes pertaining to the related equipment. Environmental conditions should also be reviewed. Proper ventilation and cooling must be adequate for optimum battery life and performance. A clearance of 4" is recommended at the front and rear of the cabinet. This refers to obstruction of ventilation only. Clearance around the cabinet sides should be as suggested by NEC and local codes. Ambient temperature should be between 68°F -77°F.

7.2 Cabinet Mounting

1. Remove any remaining packaging materials (cardboard, plastic).
2. Remove the kick plate from the base of the cabinet. Save this kick plate for re-installation later.
3. Unbolt the cabinet from the pallet. Remove the cabinets from the pallet using a forklift rated for at least 5,500 lbs.
4. The battery cabinet is equipped with narrow pallet jack or forklift access openings in the front and rear of the cabinet. Move the equipment into the desired location and set in place.
Note: When applicable, the cabinet labeled "Left" has the breaker and those cabinets should be paired with any of the "Right" labeled cabinets.



5. In order to meet Zone 4 requirements, refer to the Zone 4 ANCHORING drawings included with this manual. The following steps detail the necessary actions to be taken to meet Zone 4 mounting requirements.
6. On the floor, mark the location of the 6 mounting holes found at the bottom of the cabinet legs.
7. Use the floor template or hole location drawing provided with each shipment to mark holes for anchors. Use ½" or 13mm anchors. Install anchors per manufacturer's instructions.
8. Move the cabinet into place, align holes, check levelness, and tighten hardware. **Note:** Should any drilling be performed on this equipment, make sure all exposed batteries and connections are completely covered using insulated type mats. Prevent dust from entering cabinets and clear any debris that has collected.
9. Once the cabinet is anchored to the floor, remove and discard the two shipping diagonals from the front of the cabinet.
10. Re-install the front kick plate on the cabinet.
11. Install the front doors on the cabinet.
12. If multiple battery cabinets are installed, repeat above steps. Check height and levelness with adjoining cabinets.

7.3 DC Connections

CAUTION!
PLEASE READ ALL SAFETY INSTRUCTIONS BEFORE PROCEEDING.

1. Open the cabinet door and check for any noticeable problems or damage that may have occurred during shipment. Remove the cardboard box from the cabinet (right cabinet in a dual cabinet system). Use the packing list to verify all bus bars, cables, battery covers and hardware required for assembly is available.
2. Review the installation drawing and schematic diagram included in this manual. Cables and bus bars have been left off in the battery string for safety and will need to be installed later.
3. Connect main cables to the circuit breaker, when applicable, inside the cabinet from the UPS or charger source. All cables should be sized per NEC and any other local codes pertaining to this equipment. Refer to the UPS or charger manual for wiring external batteries. **Note:** Make sure charging source is disconnected before making these connections; also verify the battery cabinet is turned off.
4. Connect the battery interconnect bus bars that were left off during shipment and install as shown on the installation drawing included in this manual. Torque connections properly. Torque values are provided on battery label.
5. Install plastic covers onto batteries. Some covers may need to be notched for locations with bus bars and/or cables in upward orientation.

7.4 Grounding

Ground the battery cabinet to the main building ground. A ground stud inside the cabinet is provided for this. For dual cabinet strings on the EFC63 and EFC53 cabinets, a bare copper bus bar is supplied to be installed between the tops of the battery cabinets. Threaded holes are provided in the cabinets for easy connection of the bus bar. Make sure a clean ground is present before bolting down bus bar.

7.5 System Operation

Refer to the UPS or charger manual for start up and operation of system.



8. SYSTEM MAINTENANCE

CAUTION!
PLEASE READ ALL SAFETY PRECAUTIONS BEFORE PROCEEDING

8.1 Blown Fuse Replacement

If a fuse has blown in the system, contact an authorized factory technician to replace it.

CAUTION! Fire Hazard Warning:
Replace only with same type and rating of fuses supplied with the system.

8.2 Battery Replacement Steps

Servicing of batteries should be performed or supervised by personnel knowledgeable about batteries and the required precautions. When replacing batteries, replace with the same type and number of batteries.

CAUTION!
Do not dispose of batteries in a fire. The batteries may explode.
Do not open or mutilate batteries. Released electrolyte is harmful to the skin and eyes.
It may be toxic.

A battery can present a risk of electrical shock and high short-circuit current. The following precautions should be observed when working on batteries:

- Remove jewelry, rings, watches or other metal objects.
 - Use tools with insulated handles.
 - Wear rubber gloves and boots. Wear safety glasses.
 - Do not lay tools or metal parts on top of batteries.
 - Disconnect charging source prior to connecting or disconnecting battery terminals.
 - Determine if the battery is inadvertently grounded. Remove string from buss and check voltages to ground. Contact with any part of a grounded battery can result in electrical shock. The likelihood of such shock can be reduced if grounds are kept during installation and maintenance (applicable to equipment and remote battery supplies not having a grounded supply circuit).
1. Prepare the new battery for installation. Check to make sure the battery is the same type and amp-hour rating. Use a non-metallic brush or scotch brite pad to clean the terminals. Apply a light coat of No-ox grease to the terminal to avoid corrosion "per battery manufacturer's recommendation".
 2. Disconnect the charger or UPS from the battery string by opening the breaker.
 3. Remove the center jumper on the battery string to reduce the voltage. If replacing all batteries, continue reducing the voltage in this manner.
 4. Disconnect the interconnect bus bars and/or cables from the battery to be replaced.
 5. Remove the old battery.
 6. Install the new battery. Make sure the new battery is installed the same way regarding polarity orientation and verify with drawing.



7. Reconnect bus bars and/or cables to the battery. Make sure connections are properly torqued. Torque values are provided on the battery label.
8. Reconnect the center jumper. Make sure connections are properly torqued. Torque values are provided on the battery label.
9. Check voltage at terminal block.
10. Close breaker when ready. If your model has a disconnect with an exterior handle to the door, close and latch the door first before closing the breaker.

9. WARRANTY RELATED MAINTENANCE

1. The purchaser (user) shall give freshening charges to the battery a minimum of every six (6) months for Lead-Calcium batteries after shipment from the factory and until final installation. Refer to the installation and maintenance instructions for maximum storage intervals at different environmental situations. Extreme heat could cause more frequent freshening charges.
2. At least once every twelve (12) months, purchaser (user) must take readings and record information per battery manufacturer's installation/maintenance instructions. These records must be maintained for warranty claim purposes. If warranty records are not kept, the warranty shall be null and void.
3. Parallel strings should be limited to five (5) strings.
4. Movement of batteries from original point of installation shall immediately void the product warranty, except with the expressed written consent from ESS.
5. Any storage shall be in a dry area having ambient temperature of 77° F (25° C), or less, and in accordance with battery manufacturer published installation, operation and maintenance instructions. Failure to follow the battery manufacturer's published guidelines and/or instructions may invalidate the product warranty, at the sole discretion of ESS.
6. During service or extended storage, a battery system monitor is recommended to be used to record temperatures, voltages, AC ripple, Float currents, Discharge and more to provide more accurate battery and environmental data for warranty with battery manufacturer's claims.



10. DRAWINGS/SCHEMATICS

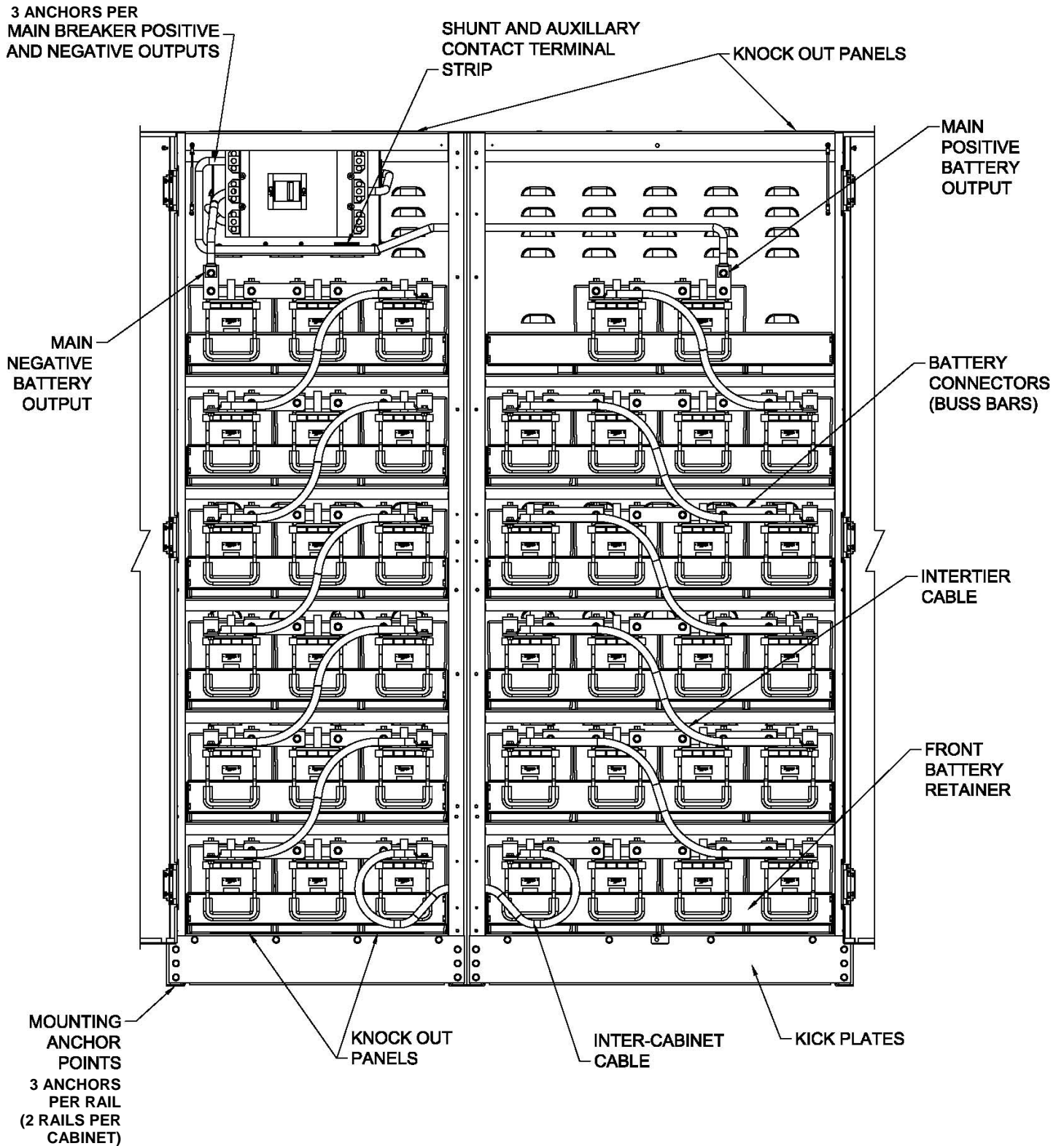

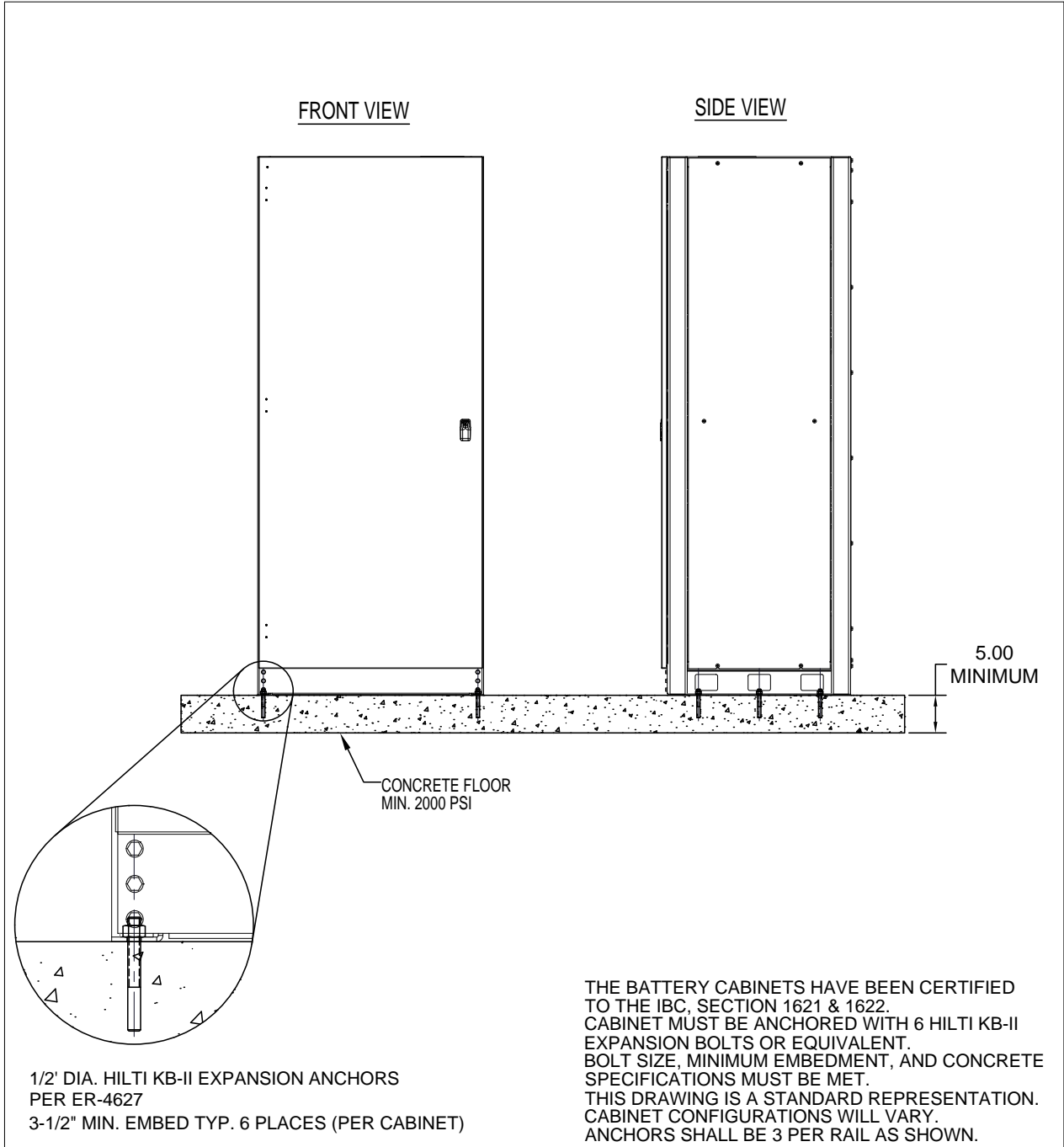

THE BATTERY CABINETS HAVE BEEN CERTIFIED TO THE IBC, SECTION 1621 & 1622. CABINET MUST BE ANCHORED WITH 6 HILTI KB-II EXPANSION BOLTS OR EQUIVALENT. BOLT SIZE, MINIMUM EMBEDMENT, AND CONCRETE SPECIFICATIONS MUST BE MET. THIS DRAWING IS A STANDARD REPRESENTATION. CABINET CONFIGURATIONS WILL VARY. ANCHORS SHALL BE 3 PER RAIL AS SHOWN.

PROPRIETARY AND CONFIDENTIAL THE INFORMATION CONTAINED IN THIS DRAWING IS THE SOLE PROPERTY OF ELECTRONIC SYSTEMS SUPPORT. ANY REPRODUCTION IN PART OR AS A WHOLE WITHOUT THE WRITTEN PERMISSION OF ELECTRONIC SYSTEMS SUPPORT IS PROHIBITED.		UNLESS OTHERWISE SPECIFIED: DIMENSIONS ARE IN INCHES	ELECTRONIC SYSTEM SUPPORT www.ess.to	3233 W. KINGSLEY RD. GARLAND, TX 75041 PH. 972-272-2468 FAX 972-276-9844				
	PROJECTION:	DRAWN		NAME	DATE	TITLE: GROUP 4D BATTERY CABINETS SEISMIC ANCHORING		
	USED ON	CHECKED		RNA	7-28-14			SIZE
	DO NOT SCALE DRAWING	ENG APPR.				A	DOC-003400	A
		MFG APPR.				SCALE: NONE		WEIGHT: N/A
	Q.A.							

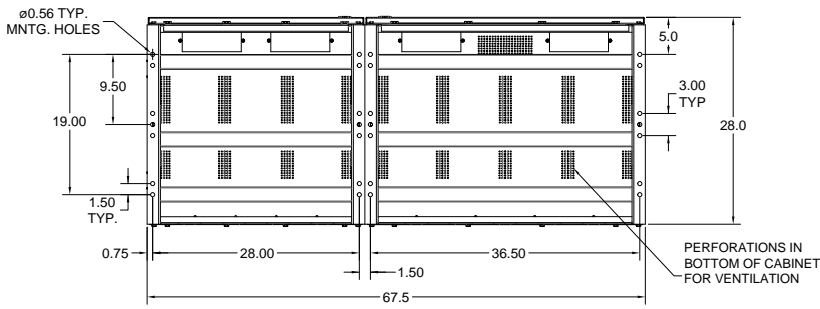

7 X 6 FOOTPRINT FOR:
 41 BLOCS, 492V
 40 BLOCS, 480V

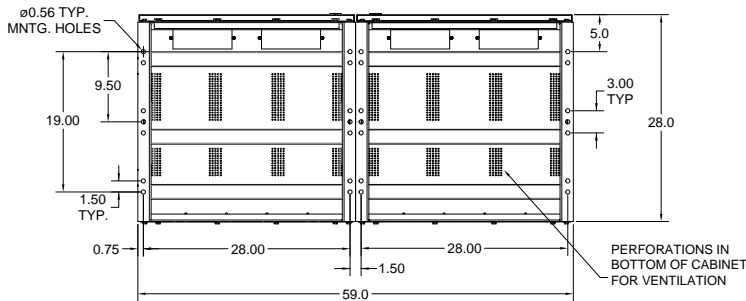

6 X 6 FOOTPRINT FOR:
 36 BLOCS, 432V
 32 BLOCS, 384V
 30 BLOCS, 360V

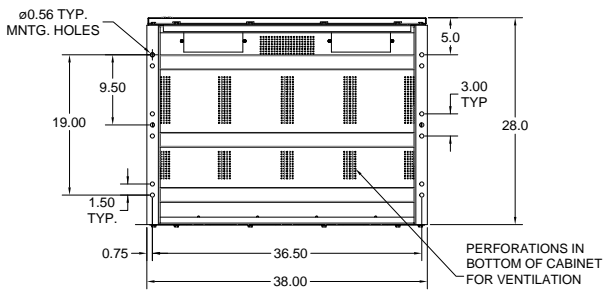

4 X 6 FOOTPRINT FOR:
 24 BLOCS, 288V

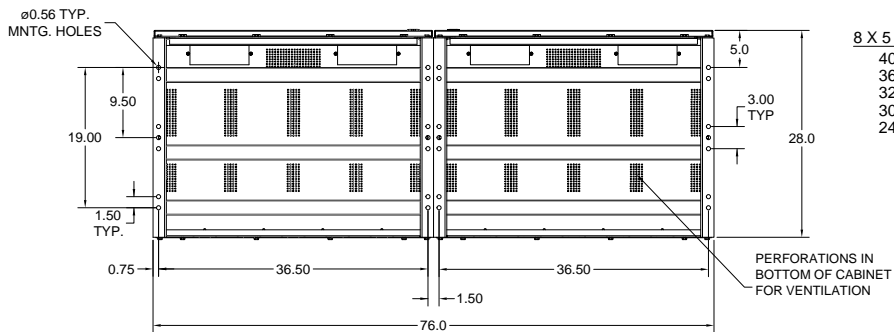

8 X 5 FOOTPRINT FOR:
 40 BLOCS, 480V
 36 BLOCS, 432V
 32 BLOCS, 384V
 30 BLOCS, 360V
 24 BLOCS, 288V

PROPRIETARY AND CONFIDENTIAL
 THE INFORMATION CONTAINED IN THIS
 DRAWING IS THE SOLE PROPERTY OF
 ELECTRONIC SYSTEMS SUPPORT. ANY
 REPRODUCTION IN PART OR AS A WHOLE
 WITHOUT THE WRITTEN PERMISSION OF
 ELECTRONIC SYSTEMS SUPPORT IS
 PROHIBITED.

	UNLESS OTHERWISE SPECIFIED:
	DIMENSIONS ARE IN INCHES
	PROJECTION:
USED ON	
	DO NOT SCALE DRAWING

	ELECTRONIC SYSTEM SUPPORT		3233 W. Kingsley Rd. Garland, TX 75041 PH. 972-272-2468 FAX 972-276-9844	
	www.ess.to			
DRAWN	NAME	DATE	TITLE:	
CHECKED	RNJ	7-30-14	GROUP 4D BATTERY CABINETS SEISMIC ANCHORING	
ENG APPR.	RNA	7-30-14	SIZE	DWG. NO.
MFG APPR.			A	DOC-003400
Q.A.			REV	A
			SCALE: NONE	WEIGHT: N/A
			SHEET 2 OF 2	



- CABINET NOTES:
1. NEMA 1 DESIGN
 2. EMPTY CABINET WEIGHT: 1070 LBS (486.4 KG) TOTAL FOR 2 CABINETS FOR 492V STRING.
 3. SEE TABLE FOR LOADED WEIGHTS

MFG	MODEL	WEIGHTS (LBS)
ENERSYS	12HX680-FR	7238
C&D	UPS12-745MRF	7402
EAST PENN	4DHR6500	6459
INTERSTATE	12M14500F	7402

BREAKER DETAIL

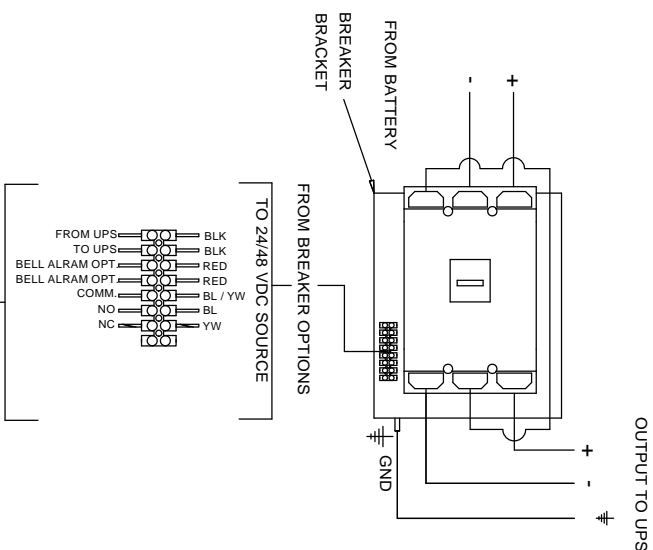

AUXILIARY CONTACTS LISTED APPLICABLE WHEN BREAKER IS IN THE CLOSED (ON) POSITION

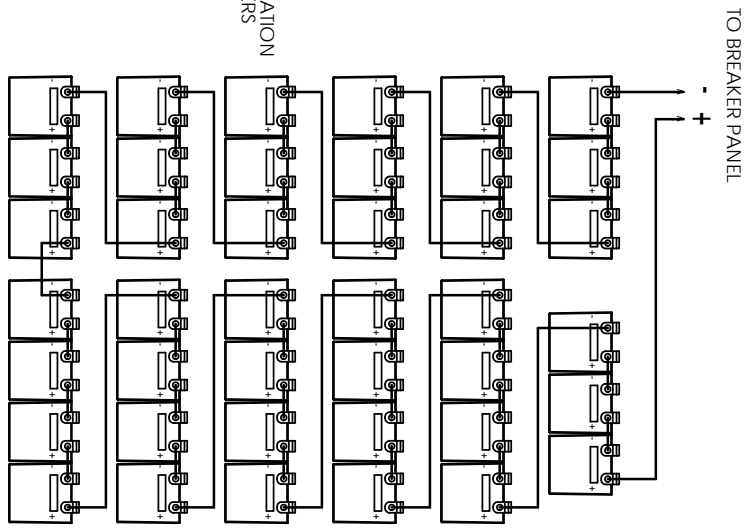
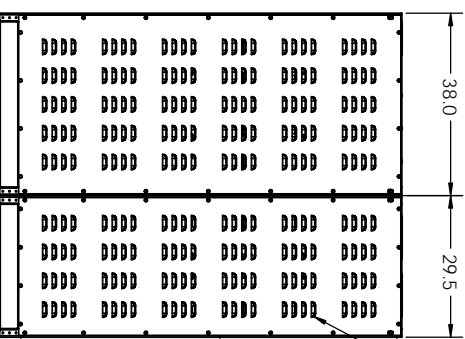
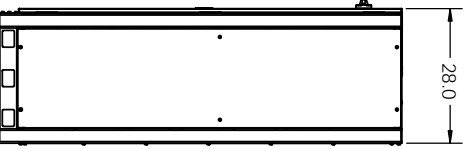
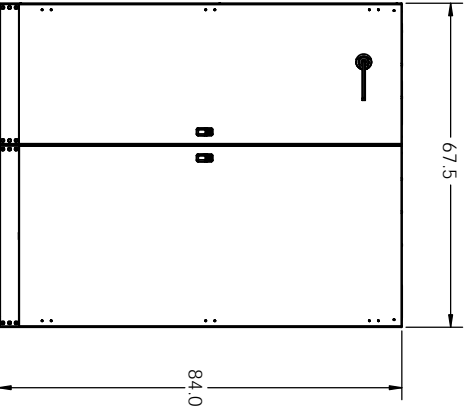
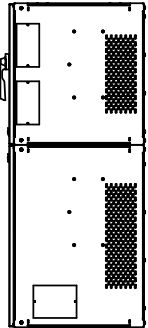
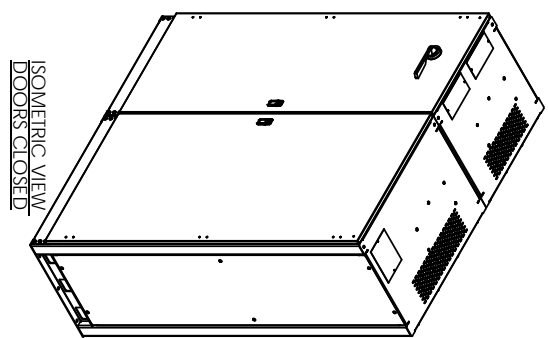

PROHIBITARY AND CONFIDENTIAL

THE INFORMATION CONTAINED IN THIS DRAWING IS THE PROPERTY OF ESS ELECTRONIC SYSTEMS SUPPORT. ANY REPRODUCTION OR TRANSMISSION OF THIS INFORMATION WITHOUT THE WRITTEN PERMISSION OF ESS ELECTRONIC SYSTEMS SUPPORT IS PROHIBITED.

3233 W. Kingsley Rd.
Garland, Texas 75041
PH. 972-272-2468
FAX 972-278-9844

ESS ELECTRONIC SYSTEMS SUPPORT
www.ess.io

DATE	01-30-17	TITLE	GROUP 4D BATTERY CABINET
DESIGNER	RWJ	GROUP	492V, 4T BLOC'S, 7 X 6
DATE	01-30-17	DWG. NO.	DOC-003500
REVISION		REV	B

PROJECTION: DO NOT SCALE DRAWING. SHEET 1 OF 1



- CABINET NOTES:
1. NEMA 1 DESIGN
 2. EMPTY CABINET WEIGHT: 1070 LBS (486.4 KG) TOTAL FOR 2 CABINETS FOR 480V STRING.
 3. SEE TABLE FOR LOADED WEIGHTS

MFG	MODEL	WEIGHTS (LBS)
ENERSYS	12HX680J-FR	7090
C&D	UPS12-745MRF	7250
EAST PENN	4DHR6500	6330
INTERSTATE	12MJ4500F	7250

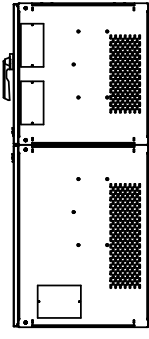

TOP VIEW

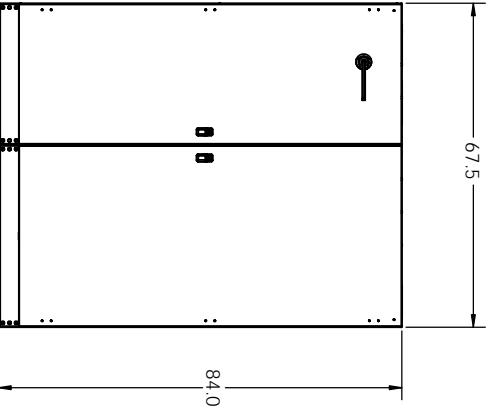

FRONT VIEW

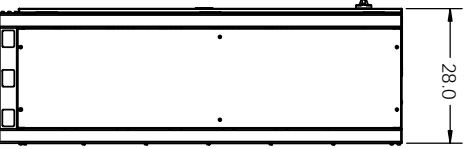

SIDE VIEW

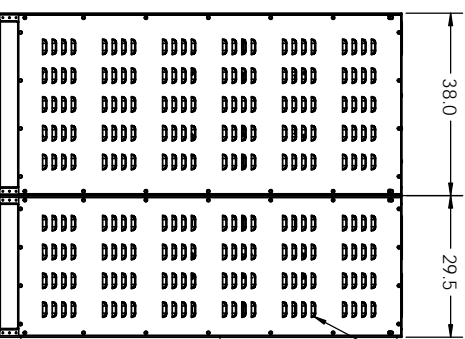

REAR VIEW

VENTILATION LOUVERS

BREAKER DETAIL

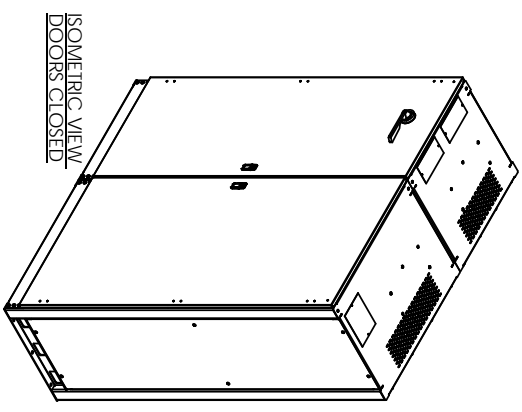
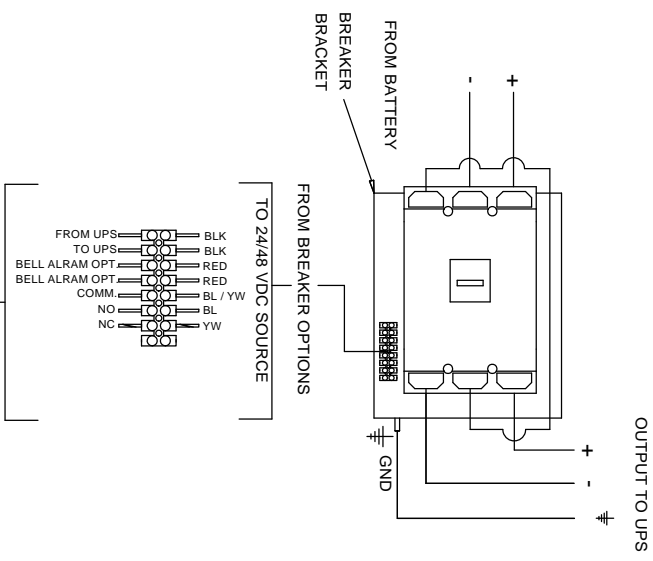

ISOMETRIC VIEW DOORS CLOSED

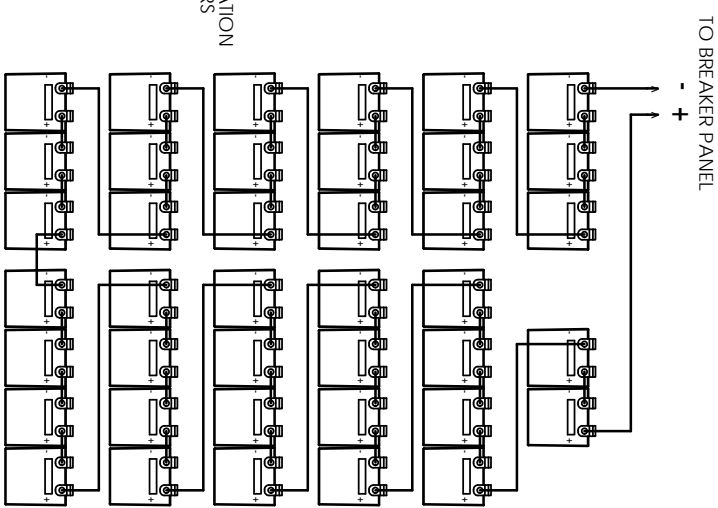

PROHIBITARY AND COMMERCIAL USE OF THIS DRAWING IS STRICTLY PROHIBITED WITHOUT THE WRITTEN PERMISSION OF ELECTRONIC SYSTEMS SUPPORT, INC.

THE INFORMATION CONTAINED IN THIS DRAWING IS THE PROPERTY OF ELECTRONIC SYSTEMS SUPPORT, INC. AND IS TO BE USED ONLY FOR THE PROJECT AND SITE SPECIFICALLY IDENTIFIED HEREIN.

ESS ELECTRONIC SYSTEMS SUPPORT
www.ess.io

3233 W. Kingsley Rd.
Garland, Texas 75041
PH: 972-272-2468
FAX: 972-278-9844

DATE	TITLE
01-30-17	GROUP 4D BATTERY CABINET
NAME	DWG. NO.
RNU	480V_40 BLOC.S_7 X 6
DATE	REV
01-30-17	B

QUISIS CHANGES SPECIFIED DIMENSIONS ARE IN INCHES

PROJECTION

DO NOT SCALE DRAWING

SHEET 1 OF 1



- CABINET NOTES:
1. NEMA 1 DESIGN
 2. EMPTY CABINET WEIGHT: 990 LBS (449 KG) TOTAL FOR 2 CABINETS FOR 432V STRING.
 3. SEE TABLE FOR LOADED WEIGHTS

MFG	MODEL	WEIGHTS (LBS)
ENERSYS	12HX680F-FR	6418
C&D	UPS12-745MRF	6562
EAST PENN	4DHR6500	5734
INTERSTATE	12MJ4500F	6562

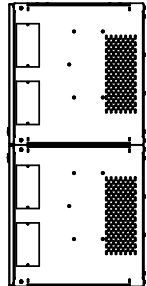

TOP VIEW

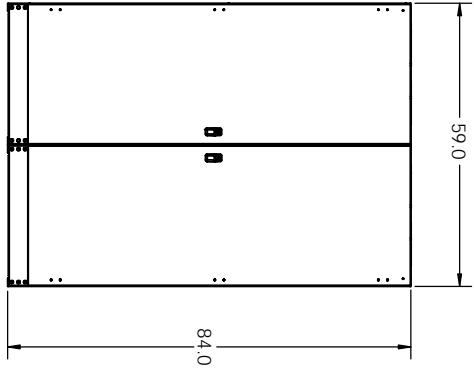

FRONT VIEW

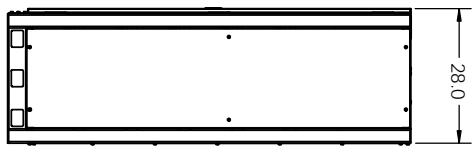

SIDE VIEW

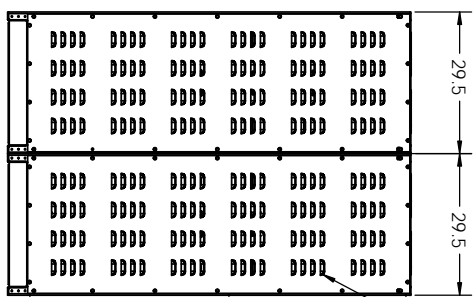

REAR VIEW

VENTILATION LOUVERS

BREAKER DETAIL

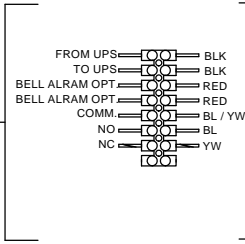
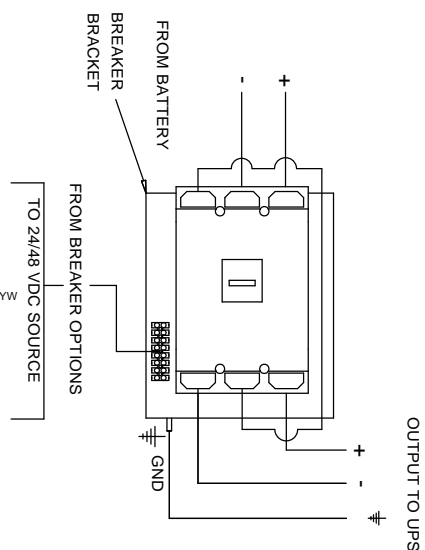

AUXILIARY CONTACTS LISTED APPLICABLE WHEN BREAKER IS IN THE CLOSED (ON) POSITION

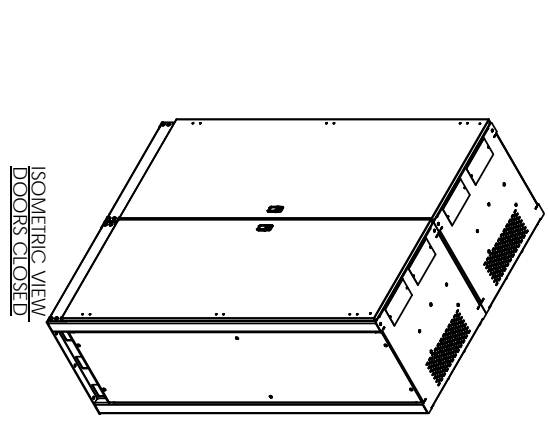

ISOMETRIC VIEW DOORS CLOSED

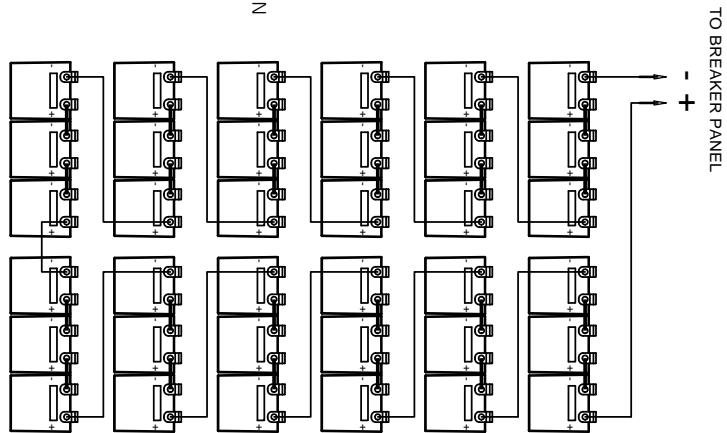

PROHIBITARY AND CONFIDENTIAL

THE INFORMATION CONTAINED IN THIS DRAWING IS UNCLASSIFIED EXCEPT WHERE SHOWN OTHERWISE. ANY REPRODUCTION OR TRANSMISSION OF THIS INFORMATION WITHOUT THE WRITTEN PERMISSION OF ELECTRONIC SYSTEMS SUPPORT IS PROHIBITED.

ESS ELECTRONIC SYSTEMS SUPPORT
www.ess.io

3233 W. Kingsley Rd.
Garland, Texas 75041
PH: 972-272-2468
FAX: 972-278-9844

DATE:	01-30-17	TITLE:	GROUP 4D BATTERY CABINET
NAME:	RWJ	DWG. NO.:	432V_36 BLOC.S_6 X 6
APPR.:		DOC. NO.:	DOC-003700
UNLESS OTHERWISE SPECIFIED, DIMENSIONS ARE IN INCHES.		REV.:	B

PROJECTION: DO NOT SCALE DRAWING. SHEET 1 OF 1



- CABINET NOTES:
1. NEMA 1 DESIGN
 2. EMPTY CABINET WEIGHT: 980 LBS (445 KG) TOTAL FOR 2 CABINETS FOR 384V STRING.
 3. SEE TABLE FOR LOADED WEIGHTS

MFG	MODEL	WEIGHTS (LBS)
ENERSYS	12HX680J-FR	5816
C&D	UPS12-745MRF	5944
EAST PENN	4DHR6500	5208
INTERSTATE	12MJ4500F	5944

BREAKER DETAIL

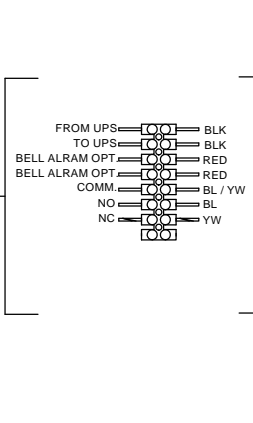
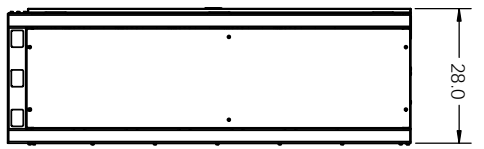
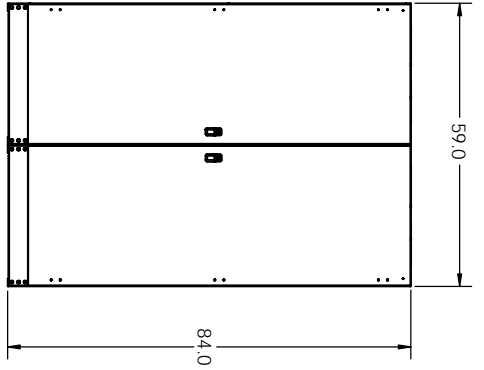
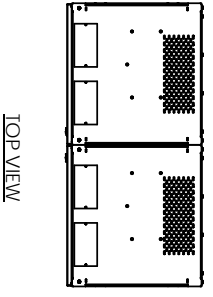
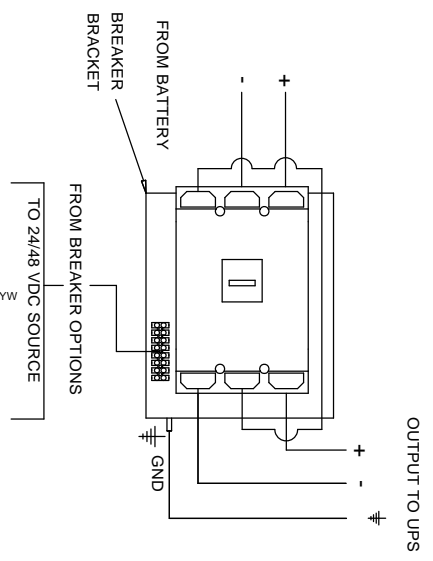

AUXILIARY CONTACTS LISTED APPLICABLE WHEN BREAKER IS IN THE CLOSED (ON) POSITION

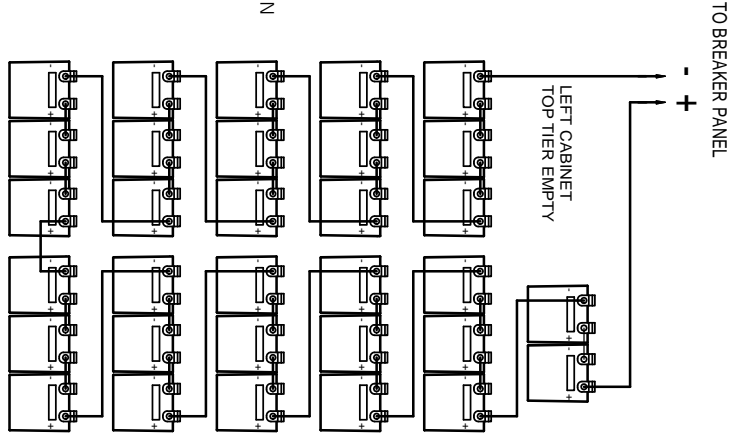
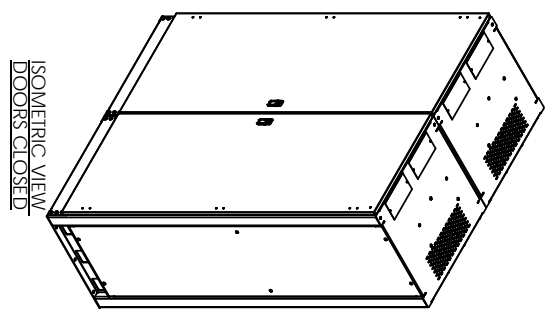
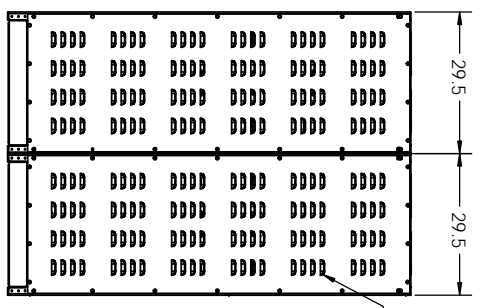

PROHIBITARY AND COMMERCIAL USE OF THIS DRAWING IS STRICTLY PROHIBITED. THE INFORMATION CONTAINED IN THIS DRAWING IS THE PROPERTY OF ESS ELECTRONIC SYSTEMS SUPPORT AND IS NOT TO BE REPRODUCED OR TRANSMITTED IN ANY FORM OR BY ANY MEANS, WITHOUT THE WRITTEN PERMISSION OF ESS ELECTRONIC SYSTEMS SUPPORT.

3233 W. Kingsley Rd.
Garland, Texas 75041
PH: 972-272-2468
FAX: 972-278-9844

ESS ELECTRONIC SYSTEMS SUPPORT
www.ess.io

DATE:	01-30-17	TITLE:	GROUP 4D BATTERY CABINET
DESIGNER:	RJW	DWG. NO.:	384V_32 BLDCS_6 X 6
APPROVER:		DOC. NO.:	DOC-003800
REVISION:		REV.:	B

PROJECTION: DO NOT SCALE DRAWING. SHEET 1 OF 1



- CABINET NOTES:
1. NEMA 1 DESIGN
 2. EMPTY CABINET WEIGHT: 970 LBS (440 KG) TOTAL FOR 2 CABINETS FOR 360V STRING.
 3. SEE TABLE FOR LOADED WEIGHTS

MFG	MODEL	WEIGHTS (LBS)
ENERSYS	12HX680F-FR	5510
C&D	UPS12-745MRF	5630
EAST PENN	4DHR6500	4940
INTERSTATE	12MW4500F	5630

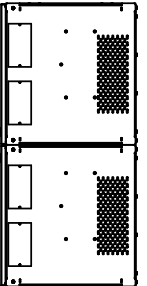

TOP VIEW

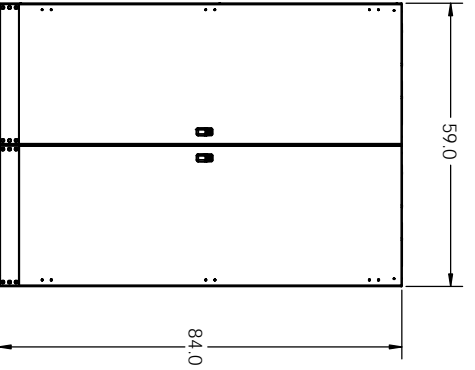

FRONT VIEW

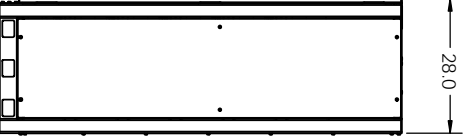

SIDE VIEW

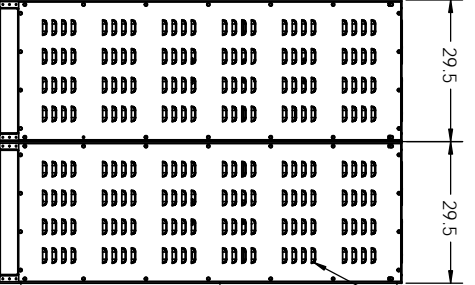

REAR VIEW

VENTILATION LOUVERS

BREAKER DETAIL

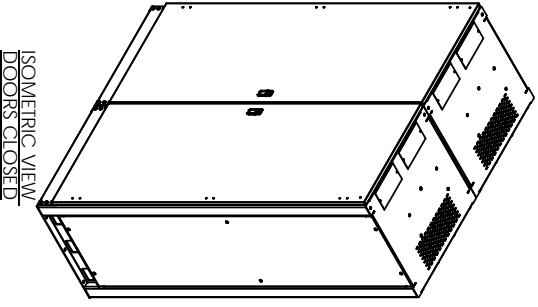
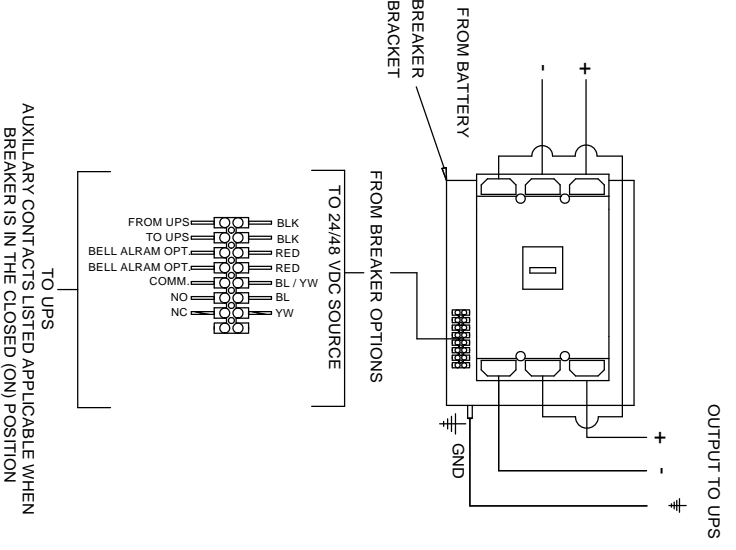

ISOMETRIC VIEW DOORS CLOSED

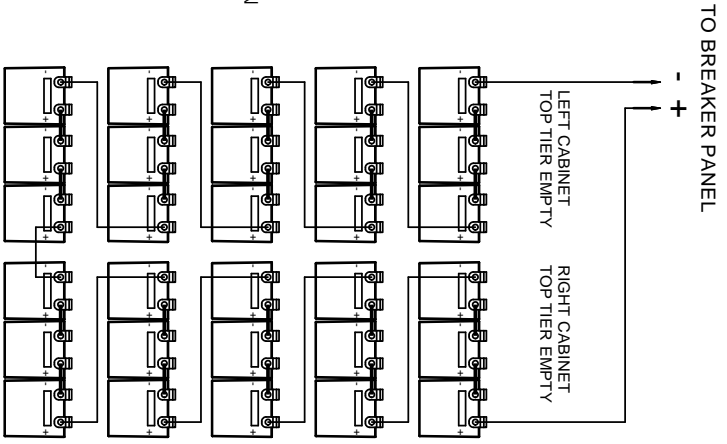

PROHIBITARY AND CONFIDENTIAL

THE INFORMATION CONTAINED IN THIS DRAWING IS THE PROPERTY OF ENERSYS. ANY REPRODUCTION OR TRANSMISSION OF THIS INFORMATION WITHOUT THE WRITTEN PERMISSION OF ENERSYS IS PROHIBITED.

ESS ELECTRONIC SYSTEMS SUPPORT
www.ess.io

3233 W. Kingsley Rd.
Garland, Texas 75041
PH: 972-272-2468
FAX: 972-272-9844

DATE:	01-30-17	TITLE:	GROUP 4D BATTERY CABINET
NAME:	RWJ	DWG. NO.:	360V_30 BLOC.S_6 X 6
APPR.:		DOC. NO.:	DOC-003900
DRAWN:		REV.:	B

PROJECTION:

DO NOT SCALE DRAWING. SHEET 1 OF 1



- CABINET NOTES:
1. NEMA 1 DESIGN
 2. EMPTY CABINET WEIGHT: 695 LBS (315 KG) TOTAL FOR 2 CABINETS FOR 288V STRING
 3. SEE TABLE FOR LOADED WEIGHTS

MFG	MODEL	WEIGHTS (LBS)
EMERSYS	12HX680F-FR	4347
C&D	UPS12-745MRF	4443
EAST PENN	4DHR6500	3891
INTERSTATE	12MJ4500F	4443

BREAKER DETAIL

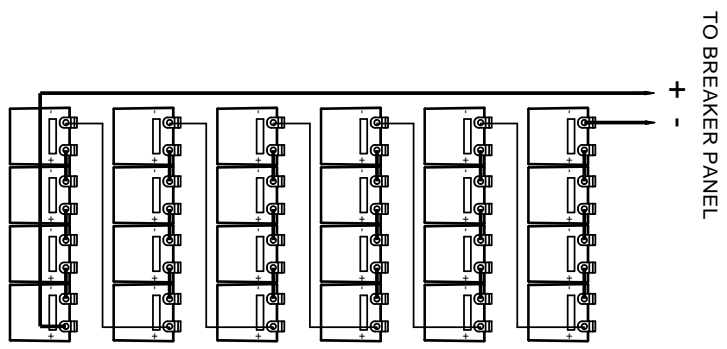
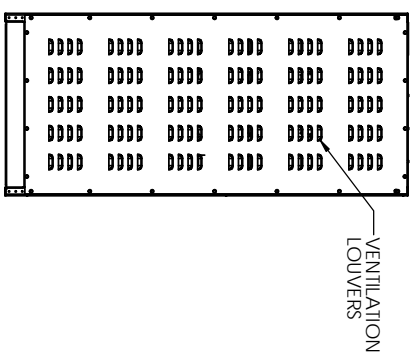
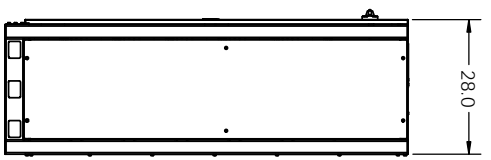
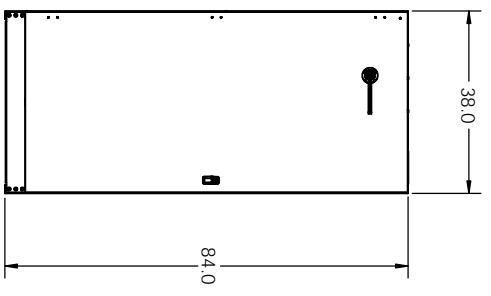
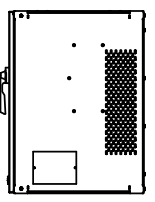
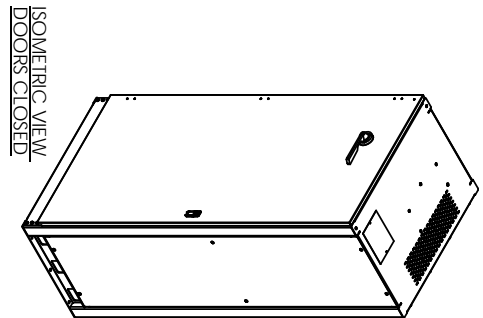
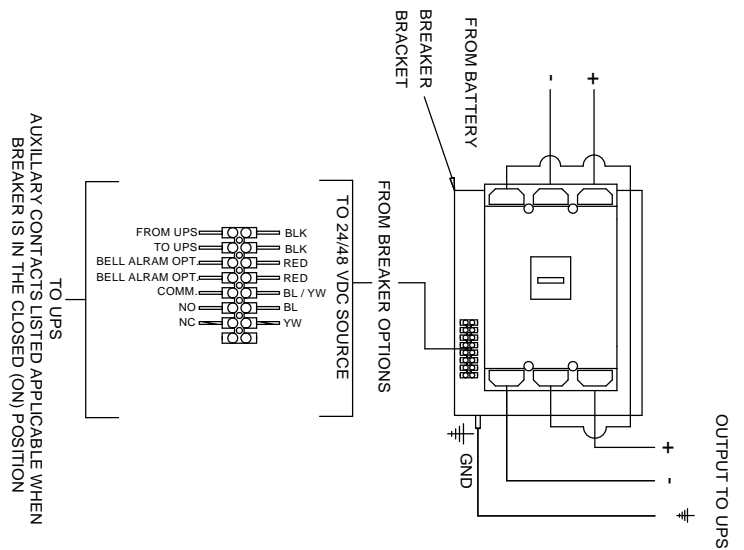

PROHIBITARY AND CONFIDENTIAL

THE INFORMATION CONTAINED IN THIS DRAWING IS THE PROPERTY OF ESS. IT IS TO BE USED FOR THE PROJECT AND SITE SPECIFICALLY IDENTIFIED HEREIN. ANY REPRODUCTION OR TRANSMISSION OF THIS INFORMATION WITHOUT THE WRITTEN PERMISSION OF ESS IS PROHIBITED.

DATE	TITLE	3233 W. Kingsley Rd. Garland, Texas 75041 PH: 972-272-2468 FAX: 972-278-9844
NAME	GROUP 4D BATTERY CABINET	
DATE	288V, 24 BLOCs, 4 X 6	
NO.	DOC-004000	
REV	B	

PROJECTION: DO NOT SCALE DRAWING. SHEET 1 OF 1



- CABINET NOTES:**
1. NEMA 1 DESIGN
 2. EMPTY CABINET WEIGHT: 1040 LBS (472 KG) TOTAL FOR 2 CABINETS FOR 480V STRING
 3. SEE TABLE FOR LOADED WEIGHTS

MFG	MODEL	WEIGHTS (LBS)
ENERSYS	12HX680F-FR	7060
C&D	UPS12-745MRF	7220
EAST PENN	4DHR6500	6300
INTERSTATE	12MM4500F	7220

BREAKER DETAIL

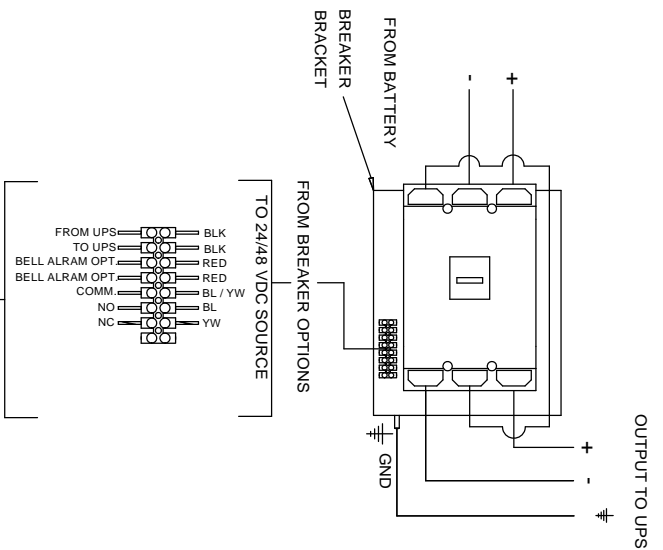

AUXILIARY CONTACTS LISTED APPLICABLE WHEN BREAKER IS IN THE CLOSED (ON) POSITION

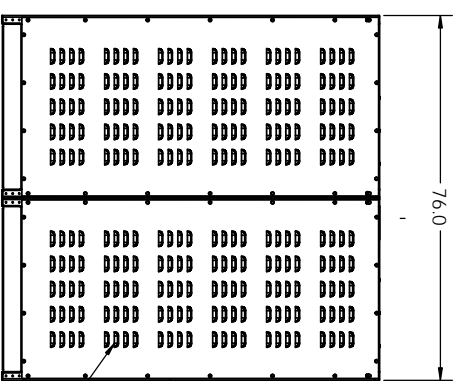
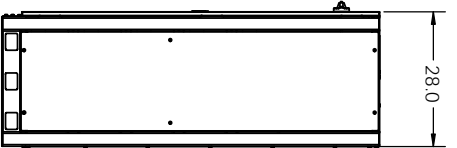
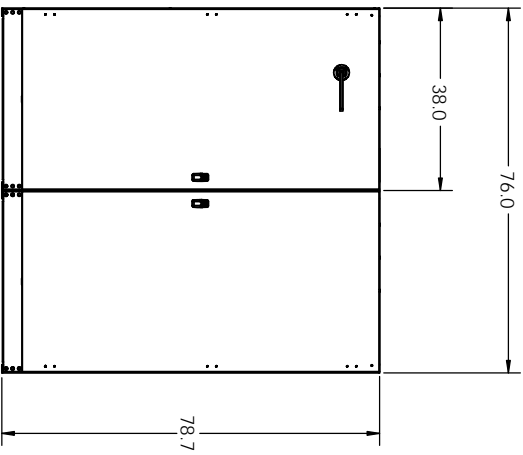
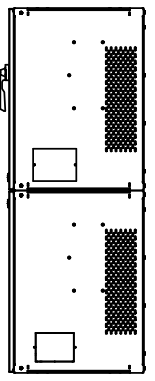
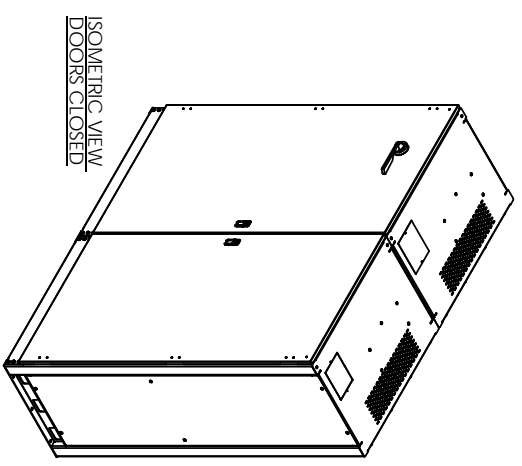

VENTILATION LOUVERS

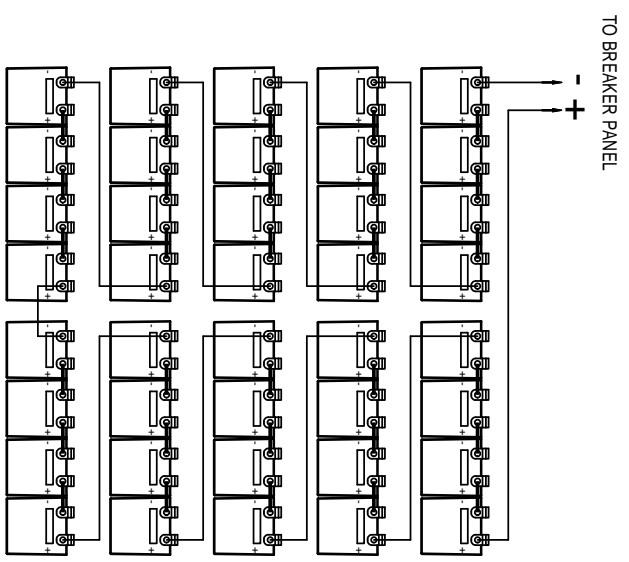

PROHIBITARY AND COMMERCIAL

THE REPRODUCTION OR COMMERCIAL USE OF THIS DRAWING WITHOUT THE WRITTEN PERMISSION OF ELECTRONIC SYSTEMS SUPPORT IS PROHIBITED.

ESS ELECTRONIC SYSTEMS SUPPORT
www.ess.io

3233 W. Kingsley Rd.
Garland, Texas 75041
PH: 972-272-2468
FAX: 972-278-9844

DATE:	01-30-17	TITLE:	GROUP 4/D BATTERY CABINET
NAME:	RWJ	DWG. NO.:	DOC-004 100
DATE:	01-30-17	REV.:	B

PROJECTION:

DO NOT SCALE DRAWING. SHEET 1 OF 1



- CABINET NOTES:
1. NEMA 1 DESIGN
 2. EMPTY CABINET WEIGHT: 1030 LBS (467 KG) TOTAL FOR 2 CABINETS FOR 432V STRING
 3. SEE TABLE FOR LOADED WEIGHTS

MFG	MODEL	WEIGHTS (LBS)
ENERSYS	12HX680J-FR	6458
C&D	UPS12-745MRF	6602
EAST PENN	4DHR6500	5774
INTERSTATE	12MM4500F	6602

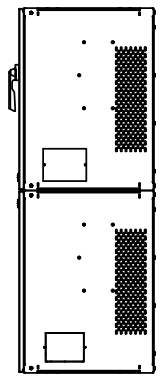

TOP VIEW

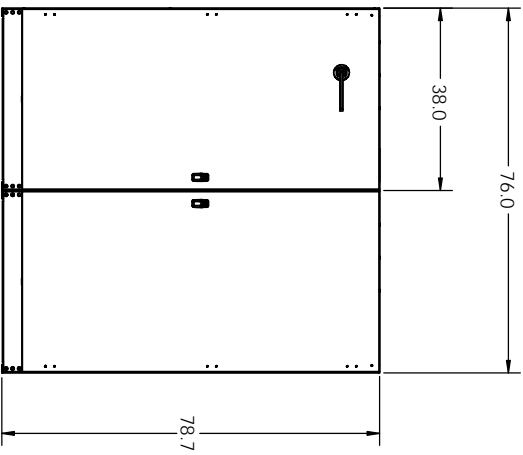

FRONT VIEW

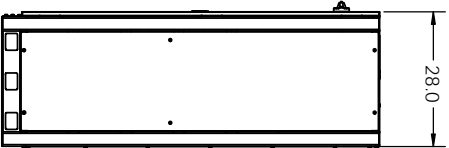

SIDE VIEW

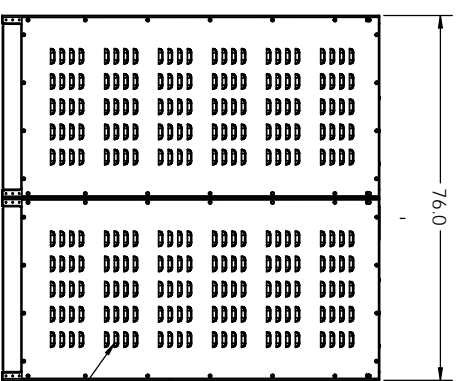

REAR VIEW

BREAKER DETAIL

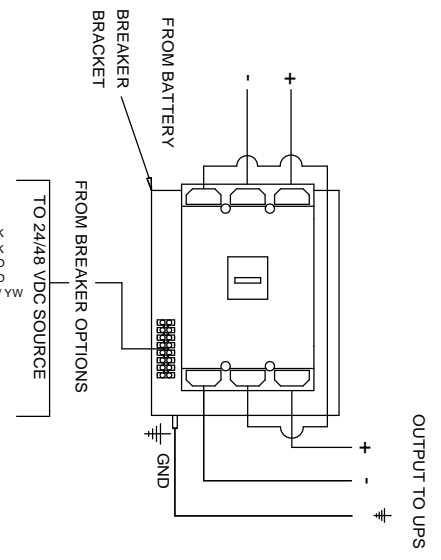
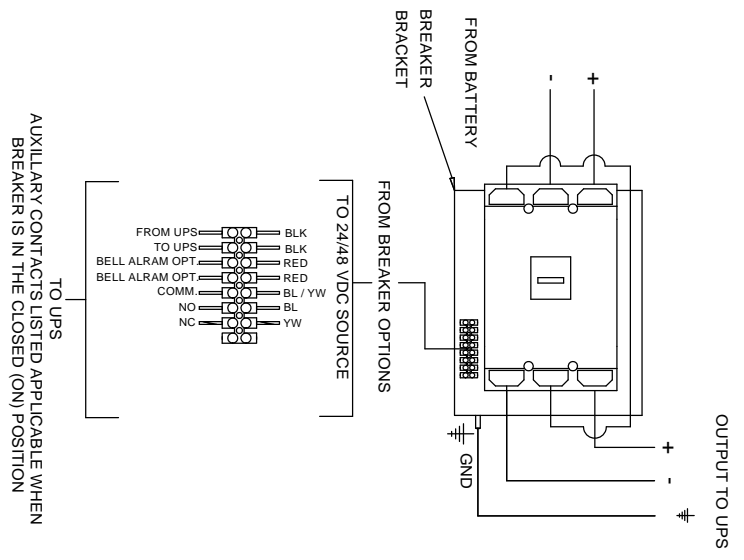

ISOMETRIC VIEW
DOORS CLOSED

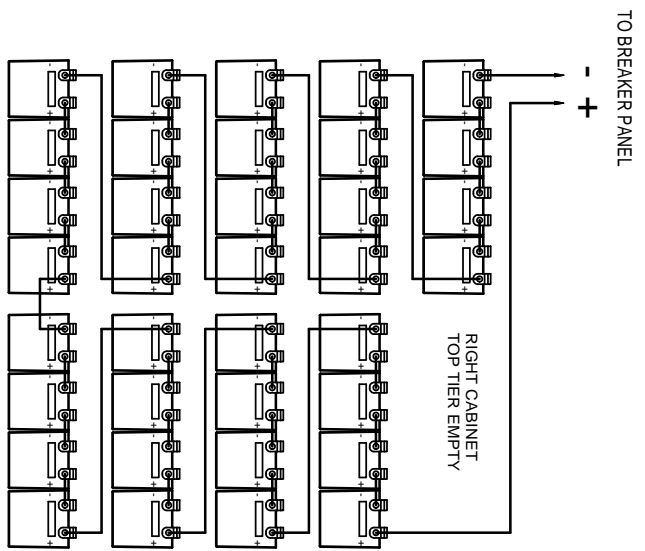

VENTILATION
LOUVERS

PROHIBITARY AND COMMERCIAL

THE INFORMATION CONTAINED IN THIS DRAWING IS THE PROPERTY OF ENERSYS. ANY REPRODUCTION OR TRANSMISSION OF THIS INFORMATION WITHOUT THE WRITTEN PERMISSION OF ENERSYS IS PROHIBITED.

ESS ELECTRONIC SYSTEMS SUPPORT
www.ess.io

3233 W. Kingsley Rd.
Garland, Texas 75041
PH: 972-272-2468
FAX: 972-278-9844

DATE:	01-30-17	TITLE:	GROUP 4D BATTERY CABINET
NAME:	RJW	DWG. NO.:	432V_36 Bl.CCS_8 X 5
APPR:		REV:	B

PROJECTION: DO NOT SCALE DRAWING. SHEET 1 OF 1



- CABINET NOTES:
1. NEMA 1 DESIGN
 2. EMPTY CABINET WEIGHT: 1020 LBS (463 KG) TOTAL FOR 2 CABINETS FOR 384V STRING
 3. SEE TABLE FOR LOADED WEIGHTS

MFG	MODEL	WEIGHTS (LBS)
ENERSYS	12HX680F-FR	5856
C&D	UPS12-745MRF	5984
EAST PENN	4DHR6500	5248
INTERSTATE	12MU4500F	5984

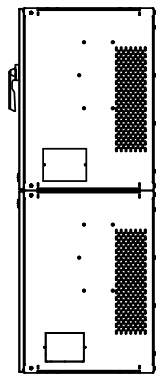

TOP VIEW

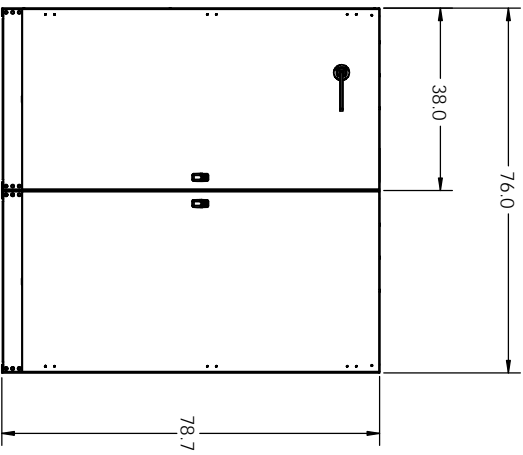

FRONT VIEW

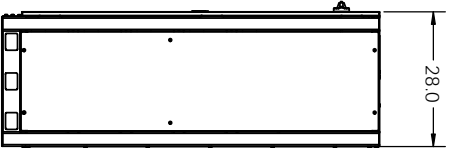

SIDE VIEW

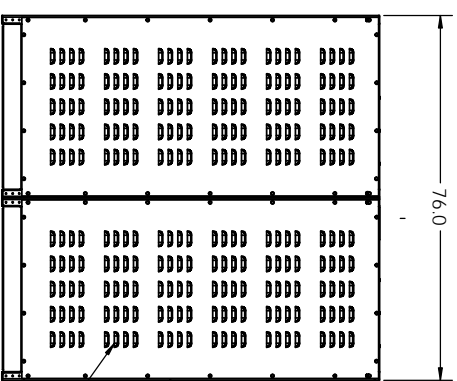

REAR VIEW

BREAKER DETAIL

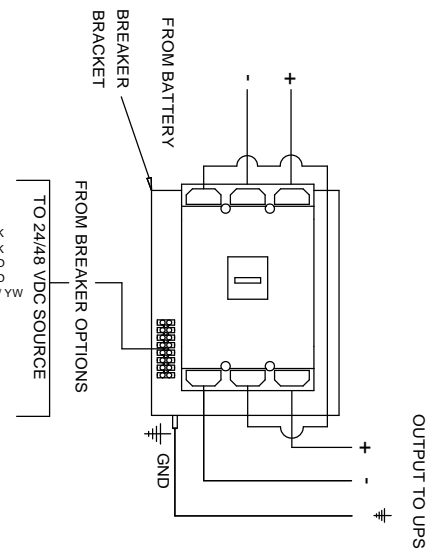
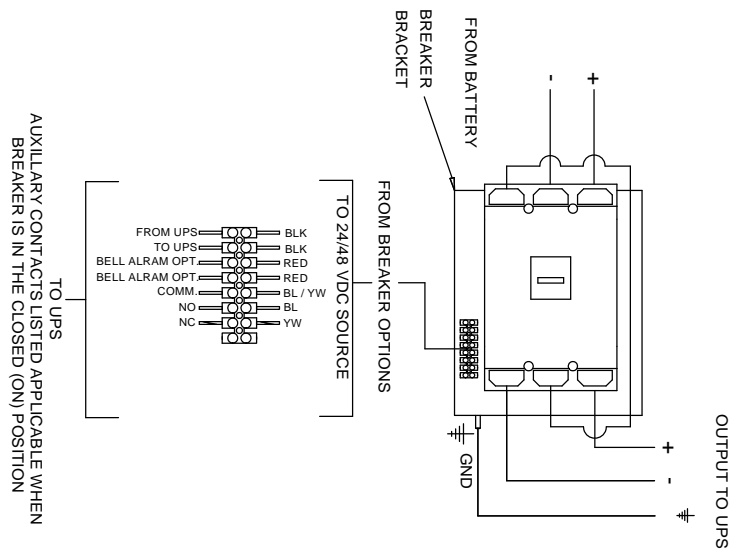

ISOMETRIC VIEW
DOORS CLOSED

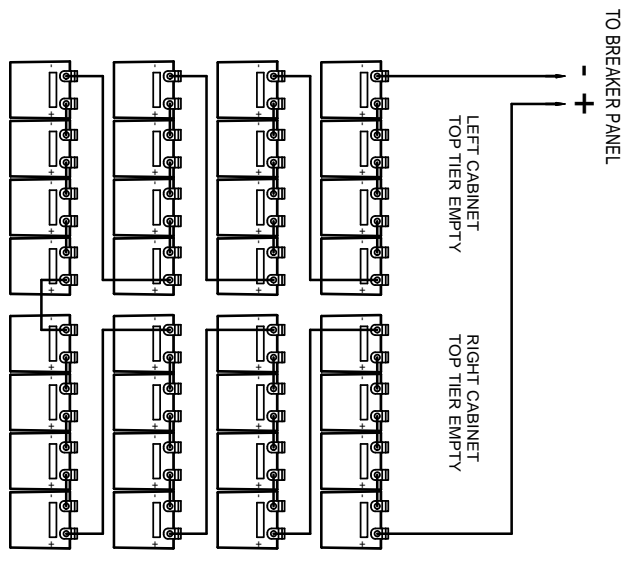

VENTILATION
LOUVERS

PROHIBITARY AND COMMERCIAL

THE INFORMATION CONTAINED IN THIS DRAWING IS THE PROPERTY OF ESS. IT IS TO BE USED ONLY FOR THE PROJECT AND SITE SPECIFICALLY IDENTIFIED HEREIN. ANY REUSE OR MODIFICATION OF THIS DRAWING WITHOUT THE WRITTEN PERMISSION OF ESS IS PROHIBITED.

ESS ELECTRONIC SYSTEMS SUPPORT
www.ess.io

3233 W. Kingsley Rd.
Garland, Texas 75041
PH: 972-272-2468
FAX: 972-278-9844

DATE:	01-30-17	TITLE:	GROUP 4D BATTERY CABINET
NAME:	RJW	DWG. NO.:	384V_32 BLDCS_8 X 4
APPR.:		DOC. NO.:	DOC-004300
DESIGNER:		REV.:	B

PROJECTION:

DO NOT SCALE DRAWING. SHEET 1 OF 1



- CABINET NOTES:**
1. NEMA 1 DESIGN
 2. EMPTY CABINET WEIGHT: 1020 LBS (463 KG) TOTAL FOR 2 CABINETS FOR 360V STRING
 3. SEE TABLE FOR LOADED WEIGHTS

MFG	MODEL	WEIGHTS (LBS)
ENERSYS	12HX680J-FR	5560
C&D	UPS12-745MRF	5680
EAST PENN	4DHR6500	4990
INTERSTATE	12M14500F	5680

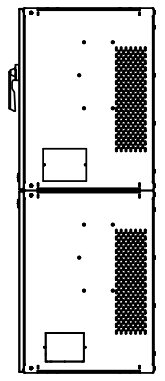

TOP VIEW

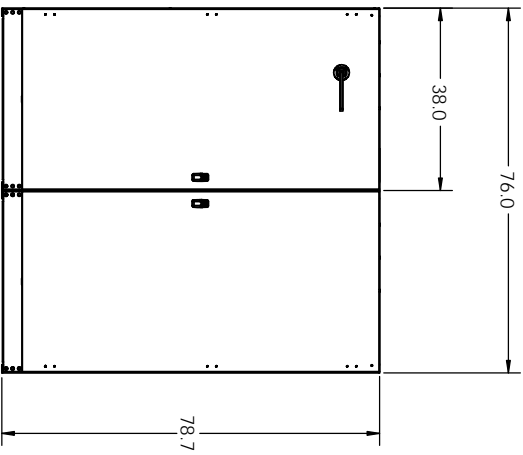

FRONT VIEW

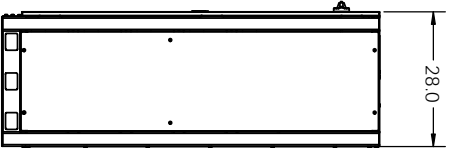

SIDE VIEW

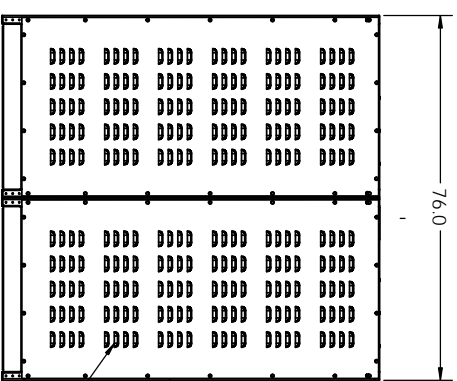

REAR VIEW

BREAKER DETAIL

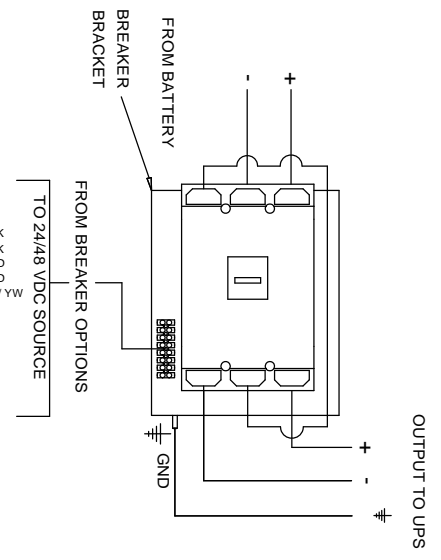
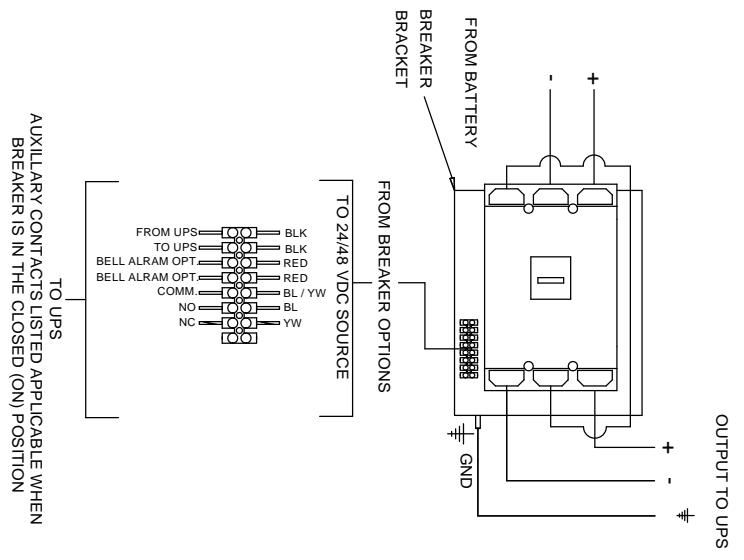

ISOMETRIC VIEW
DOORS CLOSED

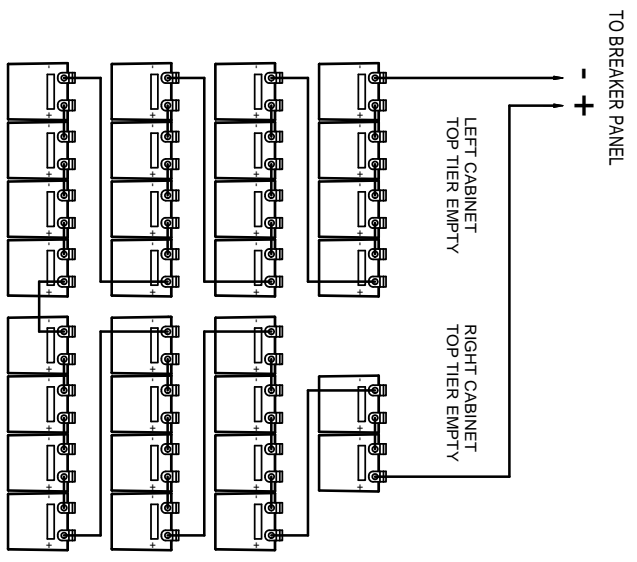

VENTILATION LOUVERS

PROHIBITARY AND COMMERCIAL

THE REPRODUCTION OR TRANSMISSION OF THIS DOCUMENT IN ANY FORM OR BY ANY MEANS WITHOUT THE WRITTEN PERMISSION OF ENERSYS IS PROHIBITED.

ESS ELECTRONIC SYSTEMS SUPPORT
www.ess.io

3233 W. Kingsley Rd.
Garland, Texas 75041
PH: 972-272-2468
FAX: 972-278-9844

NAME:	DATE:	TITLE:
REV:	APPR:	GROUP: 4D BATTERY CABINET
DWG. NO.:	360V, 30 BLOC'S, 8 X 4	
DOC-004400		
PROJECTION:	DO NOT SCALE DRAWING:	SHEET 1 OF 1



- CABINET NOTES:
1. NEMA 1 DESIGN
 2. EMPTY CABINET WEIGHT: 1000 LBS (454 KG) TOTAL FOR 2 CABINETS FOR 288V STRING
 3. SEE TABLE FOR LOADED WEIGHTS

MFG	MODEL	WEIGHTS (LBS)
ENERSYS	12HX680F-FR	4652
C&D	UPS 12-745MRF	4748
EAST PENN	4DHR6500	4196
INTERSTATE	12MJ4500F	4748

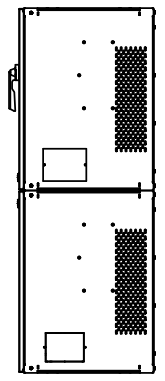

TOP VIEW

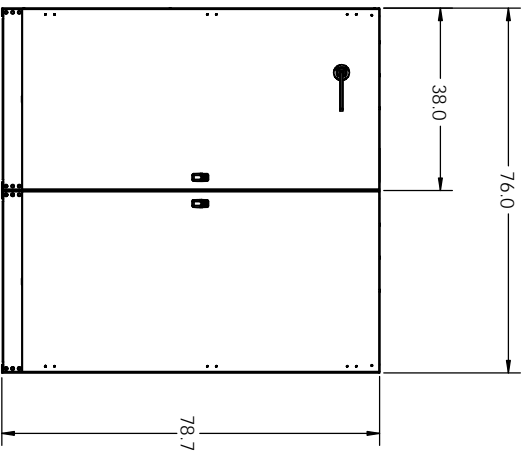

FRONT VIEW

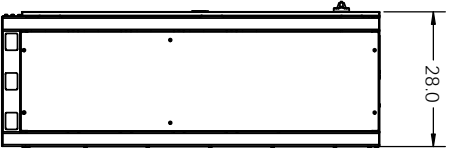

SIDE VIEW

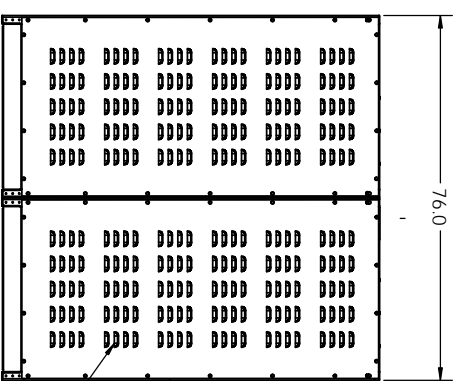

REAR VIEW

BREAKER DETAIL

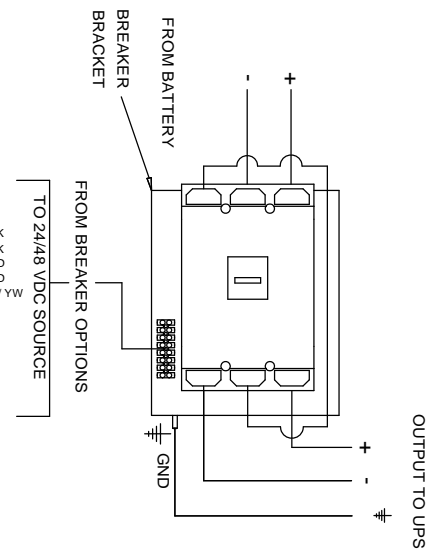
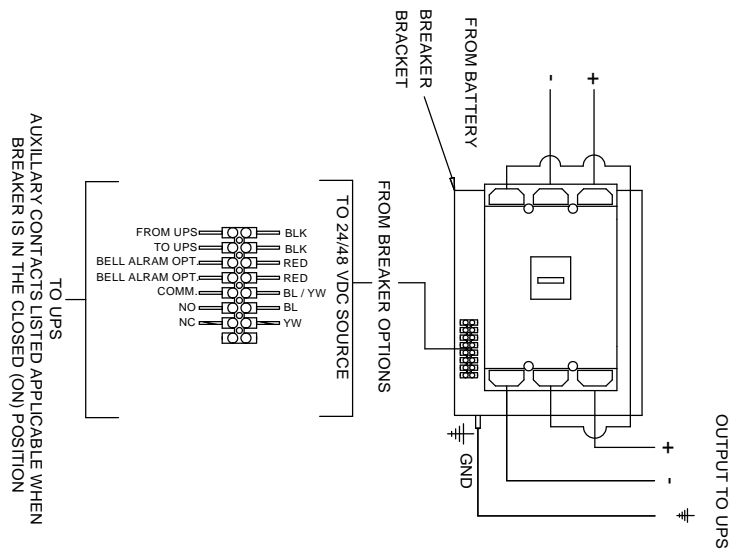

ISOMETRIC VIEW
DOORS CLOSED

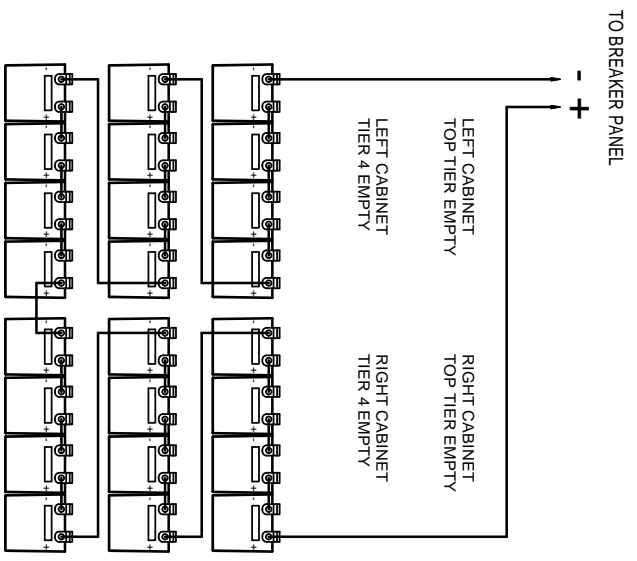

VENTILATION
LOUVERS

PROHIBITARY AND COMMERCIAL USE OF THIS DRAWING IS STRICTLY PROHIBITED. THE USER ASSUMES ALL LIABILITY FOR ANY DAMAGE TO PERSONS OR PROPERTY CAUSED BY THE USE OF THIS DRAWING. THE USER SHALL INDEMNIFY AND HOLD HARMLESS THE DRAWING PROVIDER FROM AND AGAINST ALL SUCH DAMAGES.

ESS ELECTRONIC SYSTEMS SUPPORT
www.ess.io

3233 W. Kingsley Rd.
Garland, Texas 75041
PH: 972-272-2468
FAX: 972-278-9844

DATE:	01-30-17	TITLE:	GROUP 4D BATTERY CABINET
NAME:		DWG. NO.:	288V_24 BLOCs_8 X 4
APPR:		DOC. NO.:	DOC-004500
DRAWN:		REV:	B

PROJECTION: DO NOT SCALE DRAWING. SHEET 1 OF 1



NOTES



NOTES



3233 W. Kingsley Rd. • Garland, TX 75041 • Ph: 972-272-2468 • Fax: 972-272-276-9844 • www.ess.to